

ACE OF SPADES

Ed. 02-2019



Catalogo ricambi
Spare parts catalog
Catalogue pieces de rechange
Ersatzteilkatalog
Catalogo piezas de repuestos



INFORMAZIONI GENERALI

Il presente catalogo serve per richiedere con esattezza le parti di ricambio
Nelle ordinazioni indicare:

- 1) il numero di codice dei particolari seguito dalla descrizione;
- 2) il colore per i pezzi verniciati o comunque colorati;
- 3) il numero di matricola del motociclo, stampigliato sul canotto di sterzo.

Le indicazioni destra e sinistra si riferiscono ai lati del veicolo rispetto al senso di marcia;

Dati indicativi soggetti a modifiche senza impegno di preavviso.

All data are subject to modification without prior notice.

Données indicatif sujet au modifications sans obligation de préavis.

Anderungen vorbehalten.

Datos indicativos sujetos a modificaciones sin compromiso de preaviso.

GENERAL INFORMATION

The present spare parts list enables one to order exactly the right spare parts.

When ordering specify:

- 1) the part's code number followed by its description;
- 2) indicate colour for painted or coloured parts;
- 3) the motorcycle's serial number, stamped on the steering head.

References to right and left apply to the vehicle in terms of its direction of movement.

NOTE - LIST - NOTES - NOTE - NOTAS:

AUS : Australia, Australia, Australie, Australien, Australia

CDN : Canada, Canada, Canada, Kanada, Canadá

IT : Italia, Italy, Italie, Italien, Italia

JAP : Giappone, Japan, Japon, Japan, Japón

USA : Stati Uniti d'America, United States of America, Etats Units d'Amerique, Vereinigte Staaten von Amerika, Estados Unidos

INFORMATIONS GENERALES

Ca catalogue permet de commander correctement les pièces de rechange.

Les commandes doivent être passées en indiquant:

- 1) le numéro de code des pièces détachées suivi de leur description;
- 2) le couleur des pièces peintes ou colorés;
- 3) le matricule de la moto, estampillé sur la tige du guidon.

Droite et gauche sont les côtés du véhicule par rapport au sens de la marche.

ALLGEMEINE HINWEISE

Dieser Ersatzteilkatalog dient zur genauen Angabe der Teile bei Ersatzteilbestellungen.

Bei Ersatzbestellung ist folgendes anzugeben:

- 1) Die Bestellnummer der Ersatzteile mit der entsprechenden Beschreibung;
- 2) Farbe für lackierte und farbige Teile angeben;
- 3) Die Sseriennummer des Motorrads, die am Lenkrohr eingepreßt ist.

Die Angaben rechts und links beziehen sich auf das Fahrzeug in Fahrrichtung.

INFORMACIONES GENERALES

El presente catálogo sirve para pedir con exactitud las partes de recambio.

En los pedidos se debe indicar:

- 1) el número de código de la parte y a continuación la descripción;
- 2) el color para las piezas barnizadas o coloreadas;
- 3) el número de matrícula de la motocicleta, estampado en el tubo de dirección.

Las indicaciones derecha e izquierda se refieren a los lados del vehículo respecto del sentido de marcha.

N° DI MATRICOLA INIZIALE - INITIAL SERIAL NUMBER - MATRICULE
INITIAL - BEGINNTESEIENNUMMER - MATRICULA INICIAL

MODELLO - MODEL
MODELE - MODELL
MODELO

MATRICOLA - SERIAL NUMBER
MATRICULE - SERIENNUMMER
MATRICULA

ACE OF SPADES

ZN0B300ABHV000001



INDICE – INDEX – INDEX – INHALTSVERZEICHNIS - INDICE

ACE OF SPADES

Tavola Drawing Table Bild Tabla	Denominazione	Description	Designation	Bezeichnung	Denominacion	Pagina Page Seite Paja
1	ATTREZZI DI ASSISTENZA, MANUALI E DOTAZIONI	SERVICE TOOLS, MANUALS AND EQUIPMENT	OUTILS D'ASSISTANCE, MANUELS ET EQUIPEMENT	HILFAUSRUSTUNG, HANDBUCH UND DOTIERUNG	HERRAMIENTAS DE ASISTENCIA, MANUALES Y EQUIPAMIENTO	13
2	CILINDRO, PISTONE	CYLINDER, PISTON	CYLINDRE, PISTON	ZYLINDER, KOLBEN	CILINDRO, PISTON	15
3	TESTA CILINDRO	CYLINDER HEAD	CULASSE	ZYLINDERKOPF	CULATA	17
4	COPERCHIO VALVOLE	VALVE COVER	COUVERCLE CULASSE	ZYLINDERKOPFDECKEL	TAPA CULATA	19
5	MANOVELLISMO	CRANKSHAFT	VILEBREQUIN	KURBELWELLE	CIGÜEÑAL	21
6	DISTRIBUZIONE	VALVE TIMING	DISTRIBUTION	VENTILSTEUERUNG	DISTRIBUCION	23
7	LUBRIFICAZIONE	OIL PUMP	PUMPE HUILE	MOTORSCHMIERUNG	LUBRICACION	25
8	COPERCHIO CARTER SINISTRO	LEFT CRANKCASE COVER	COUVERCLES CARTER GAUCHE	GEHAUSEDECKEL LINKS	TAPAS BANCADA IZQUIERDA	27
9	SEMICARTER SINISTRO	LEFT HALF CRANKCASE	CARTER GAUCHE	GEHAUSEDECKEL LINKS	BANCADA IZQUIERDA	29
10	SEMICARTER DESTRO	RIGHT HALF CRANKCASE	CARTER DROIT	GEHAUSEDECKEL RECHTS	BANCADA DERECHO	31
11	FRIZIONE	CLUTCH	EMBAYAGE	KUPPLUNG	EMBRAGUE	33
12	COMANDO CAMBIO	GEARSHIFT MECHANISM	COMMANDE DE VITESSE	GANGSCHALTUNG	MANDO CAMBIO	35
13	TRASMISSIONE PRIMARIA	PRIMARY DRIVE	TRANSMISSION PRIMAIRE	PRIMÄRÜBERSETZUNG	TRANSMISION PRIMARIA	37
14	PARTE ELETTRICA	IGNITION SISTEM	PARTIES ELECTRIQUE	ELEKTRISCHE TEILE	PARTE ELECTRICA	39
15	CORPO FARFALLATO	THROTTLE BODY	CORP PAPILLON	DROSSELKLAPPENKÖRPER	CUERPO OSCILANTE	41
16	FILTRO ARIA	AIR FILTER	FILTRE AIRE	LUFTFILTER	FILTRO DE AIRE	43
17	IMPIANTO RAFFREDAMENTO OLIO	OIL COOLING SYSTEM	INSTALLATION RAFROIDISSEMENT HUILE	ÖL SCHMIERUNGSSYSTEM	EQUIPO DE ENFRIAMIENTO ACEITE	45
18	SERBATOIO CARBURANTE	FUEL TANK	RESERVOIR CARBURANT	KRAFTSTOFFBEHALTER	DEPOSITO GASOLINA	47
19	PANNELLI, PARAFANGHI, SELLA	PANEL, FENDERS, SEAT	PANNEAU, GARDE-BOUES, SIEGE	STREIFEN, KOTFLUGEL, SATTEL	PANELO, GUARDABARROS, SILLIN	49
20	TELAIO, PEDANE	FRAME, FOOT RESTS	CADRE, REPOSE PIEDS	RAHMEN, FUSSBRETT	BASTIDOR, REPOSAPIES	51
20A	PEDANE E MANIGLIE PASSEGGERO	PASSENGER FOOT RESTS AND HANDLES	REPOSE PIEDS ET POIGNÉE PASSAGER	BEIFAHRRERFUßRASTE UND GRIFF	REPOSAPIES Y MANILLA ACOMPAÑANTE	55
21	MANUBRIO E COMANDI	HANDLEBAR AND CONTROLS	GUIDON ET COMMANDES	LENKER UND STEUERORGANE	MANILLAR Y MANDOS	57
22	SOSPENSIONE ANTERIORE	FRONT FORK ASSEMBLY	SUSPENSION AVANT	VORDETELESKOPGABEL	SUSPENSION DELANTERA	59
22A	FORCELLA SINISTRA	LEFT FORK	FOURCHE GAUCHE	GABEL, LINKS	HORQUILLA IZQUIERDA	61
22B	FORCELLA DESTRA	RIGHT FORK	FOURCHE DROIT	GABEL, RECHTS	HORQUILLA DERECHA	63
23	FORCELLONE E AMMORTIZZATORE POSTERIORE	REAR SWING ARM AND SUSPENSION	FOURCHE AT SUSPENSION ARRIERE	HINTERHAUFHANGUNG	HORQUILLA YSUSPENSION TRASERA	65
24	RUOTA ANTERIORE	FRONT WHEEL	ROUE AVANT	VORTERRAD	RUEDA DELANTERA	67
25	RUOTA POSTERIORE	REAR WHEEL	ROUE ARRIERE	HINTERRAD	RUEDA TRASERA	69
26	FRENO IDRAULICO ANTERIORE	FRONT HYDRAULIC BRAKE	FREIN HYDRAULIQUE AVANT	VORDERBREMSE	FRENO HIDRAULICO DELANTERO	71
27	FRENO IDRAULICO POSTERIORE	REAR HYDRAULIC BRAKE	FREIN HYDRAULIQUE ARRIERE	HINTERBREMSE	FRENO HIDRAULICO TRASERO	73
27A	IMPIANTO ABS	ABS SYSTEM	INSTALLATION ABS	ABS SYSTEM	INSTALACION ABS	75



Tavola - Drawing - Table - Bild - Tabla

1

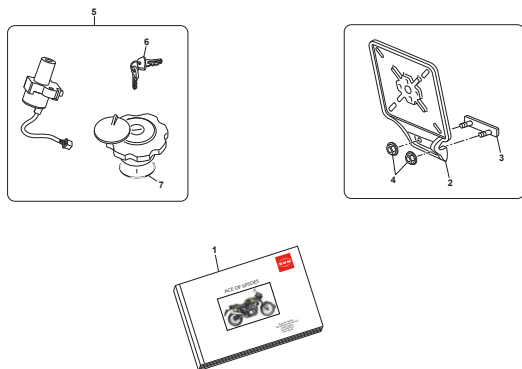

Pagina - Page - Page - Seite - Paja

12

Tavola - Drawing - Table - Bild - Tabla

2

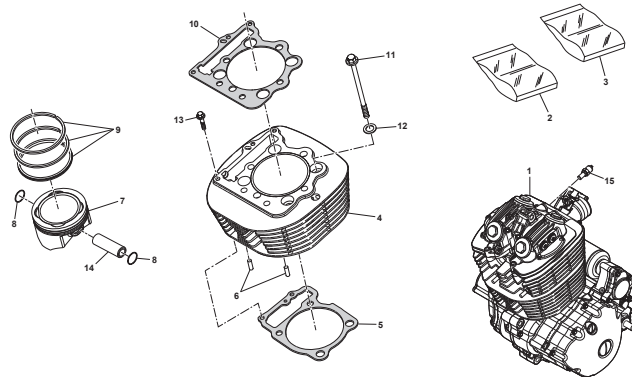

Pagina - Page - Page - Seite - Paja

14

Tavola - Drawing - Table - Bild - Tabla

3

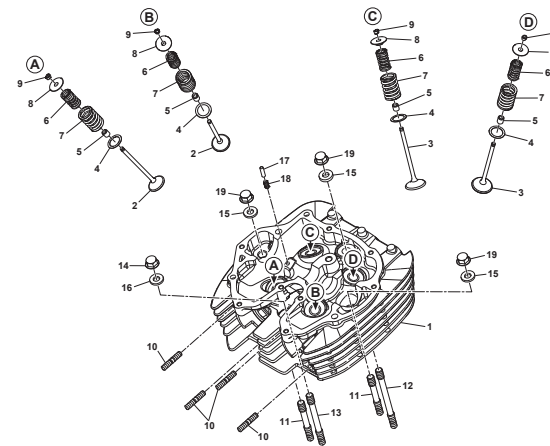

Pagina - Page - Page - Seite - Paja

16

Tavola - Drawing - Table - Bild - Tabla

4

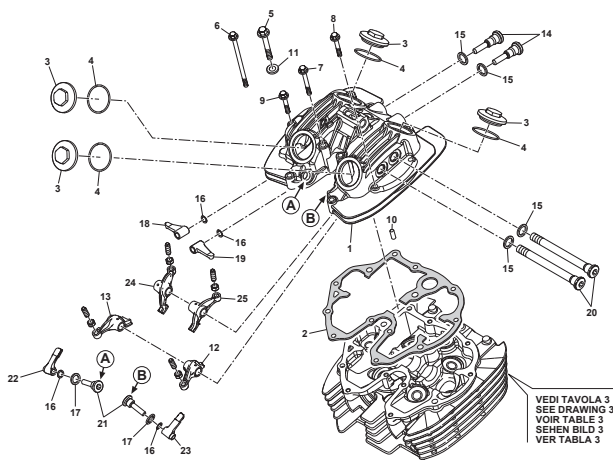

Pagina - Page - Page - Seite - Paja

18

Tavola - Drawing - Table - Bild - Tabla

5

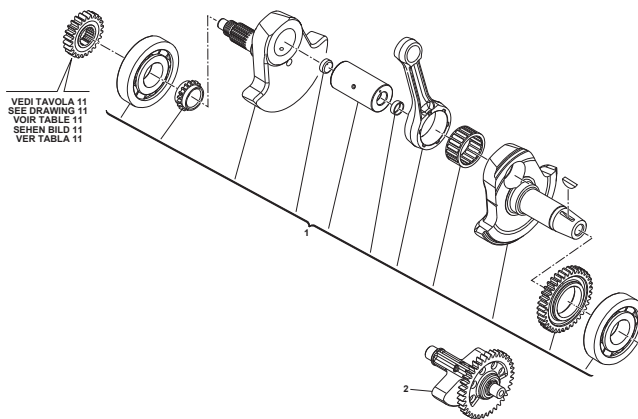

Pagina - Page - Page - Seite - Paja

20

Tavola - Drawing - Table - Bild - Tabla

6

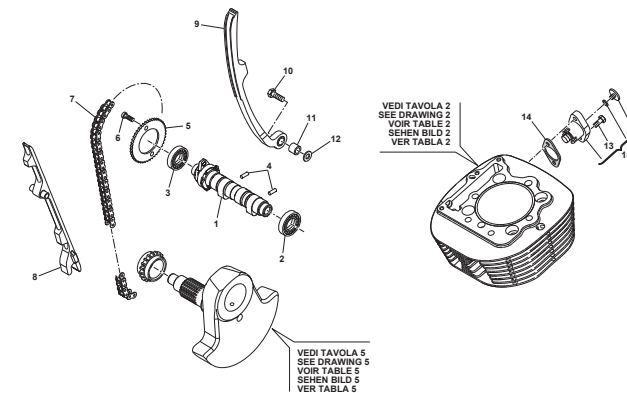

Pagina - Page - Page - Seite - Paja

22

Tavola - Drawing - Table - Bild - Tabla

7

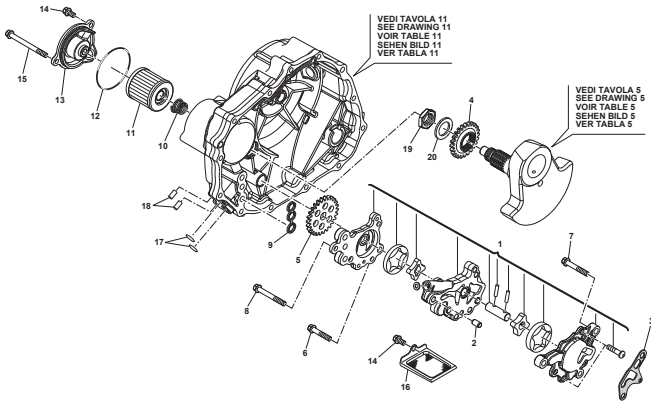

Pagina - Page - Page - Seite - Paja

24

Tavola - Drawing - Table - Bild - Tabla

8

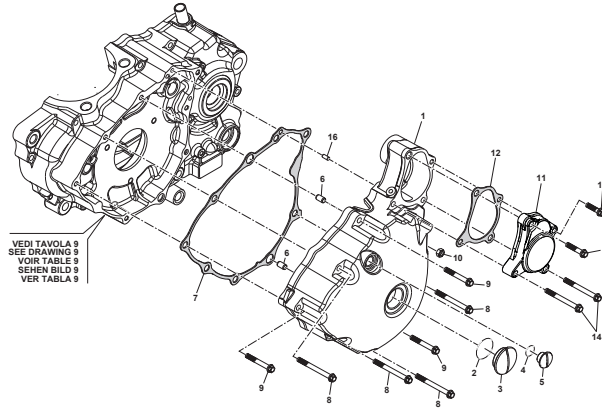

Pagina - Page - Page - Seite - Paja

26

Tavola - Drawing - Table - Bild - Tabla

9

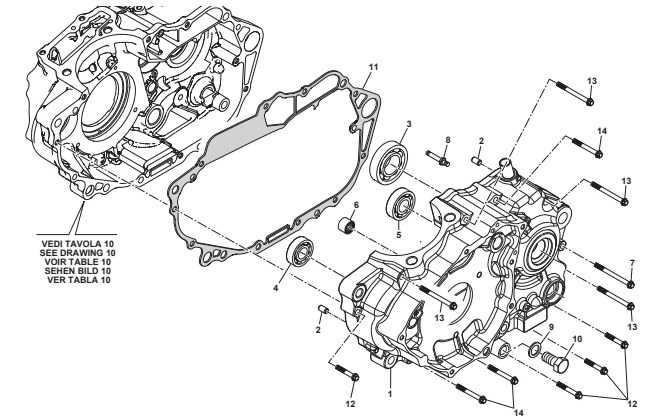

Pagina - Page - Page - Seite - Paja

28

Tavola - Drawing - Table - Bild - Tabla

10

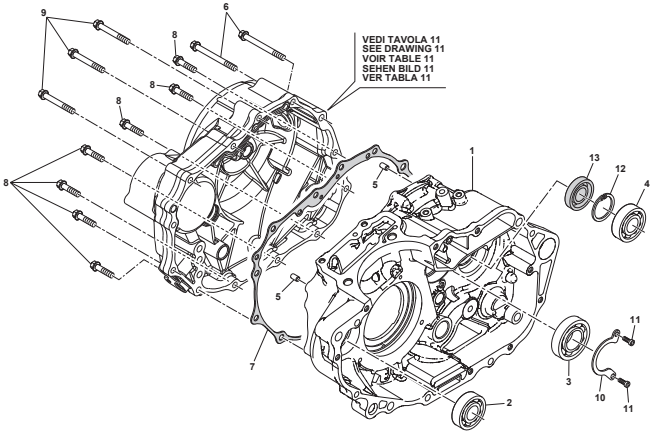

Pagina - Page - Page - Seite - Paja

30

Tavola - Drawing - Table - Bild - Tabla

11

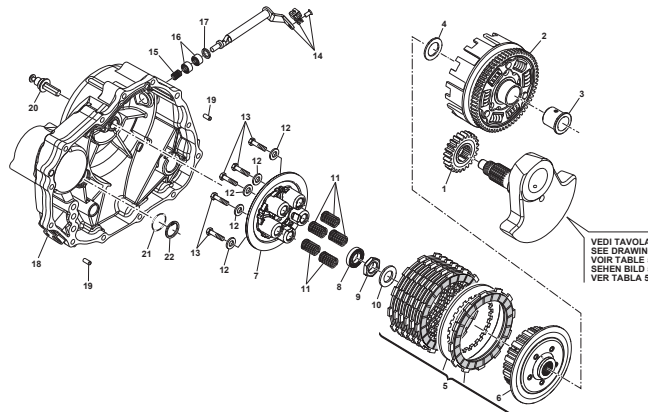

Pagina - Page - Page - Seite - Paja

32

Tavola - Drawing - Table - Bild - Tabla

12

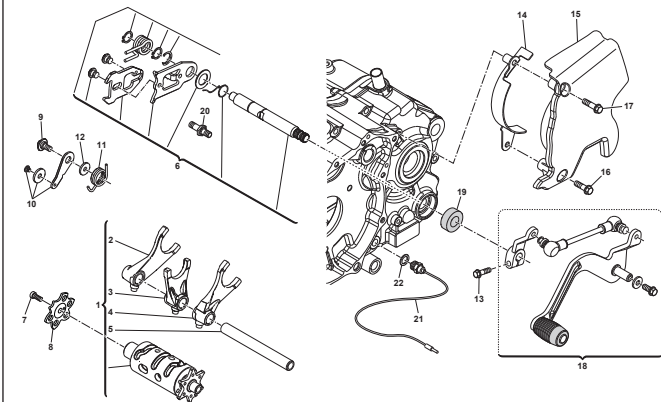

Pagina - Page - Page - Seite - Paja

34



Tavola - Drawing - Table - Bild - Tabla

13

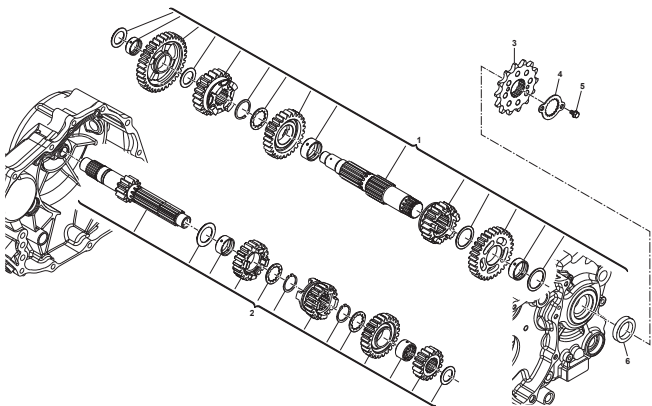

Pagina - Page - Page - Seite - Paja

36

Tavola - Drawing - Table - Bild - Tabla

14

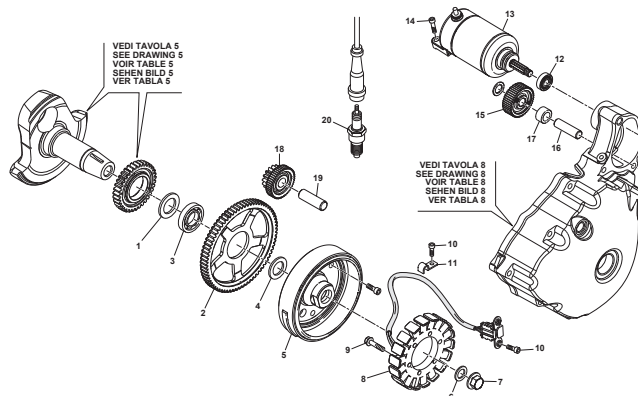

Pagina - Page - Page - Seite - Paja

38

Tavola - Drawing - Table - Bild - Tabla

15

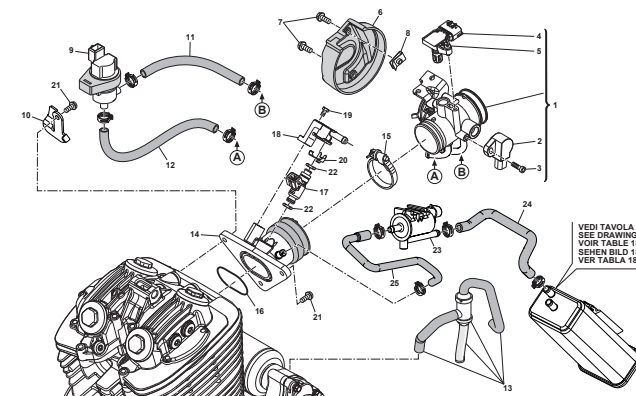

Pagina - Page - Page - Seite - Paja

40

Tavola - Drawing - Table - Bild - Tabla

16

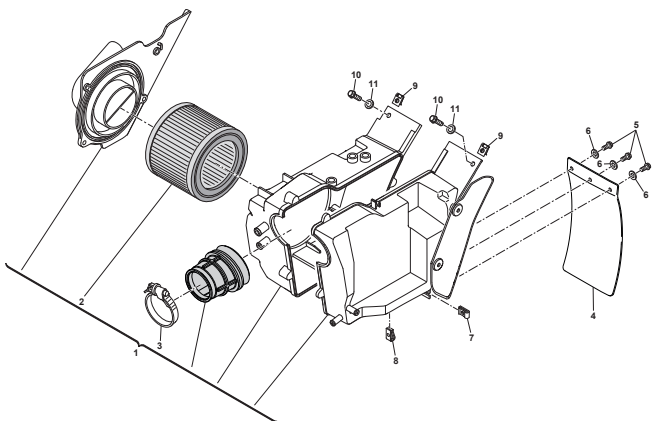

Pagina - Page - Page - Seite - Paja

42

Tavola - Drawing - Table - Bild - Tabla

17

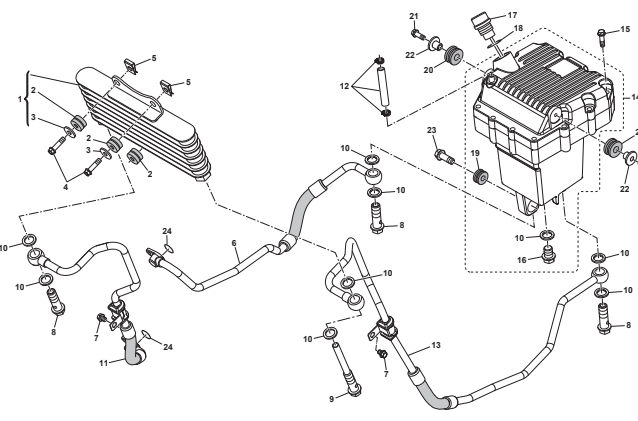

Pagina - Page - Page - Seite - Paja

44

Tavola - Drawing - Table - Bild - Tabla

18

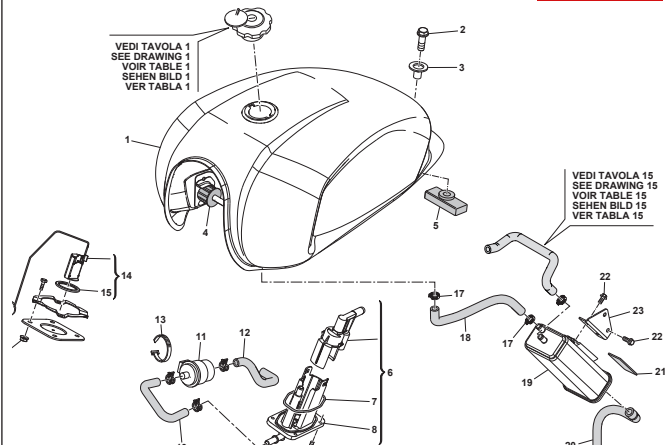

Pagina - Page - Page - Seite - Paja

46

Tavola - Drawing - Table - Bild - Tabla

19

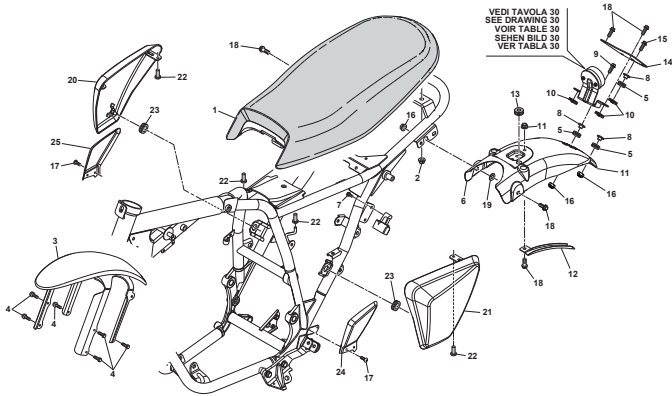

Pagina - Page - Page - Seite - Paja

48

Tavola - Drawing - Table - Bild - Tabla

20

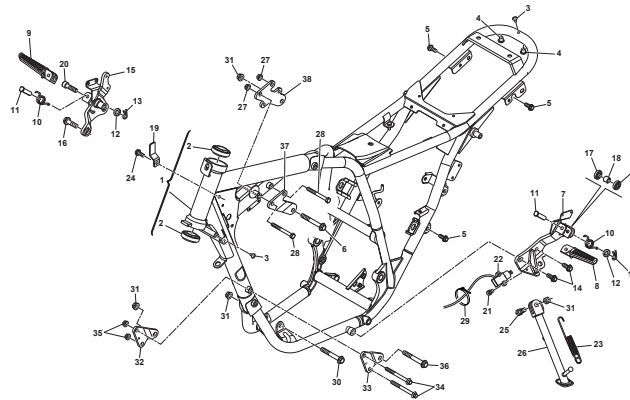

Pagina - Page - Page - Seite - Paja

50

Tavola - Drawing - Table - Bild - Tabla

20A

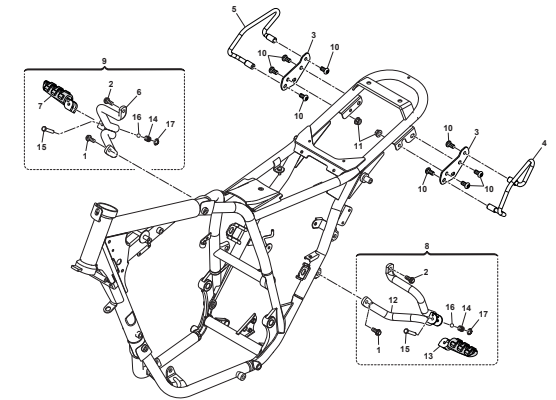

Pagina - Page - Page - Seite - Paja

54

Tavola - Drawing - Table - Bild - Tabla

21

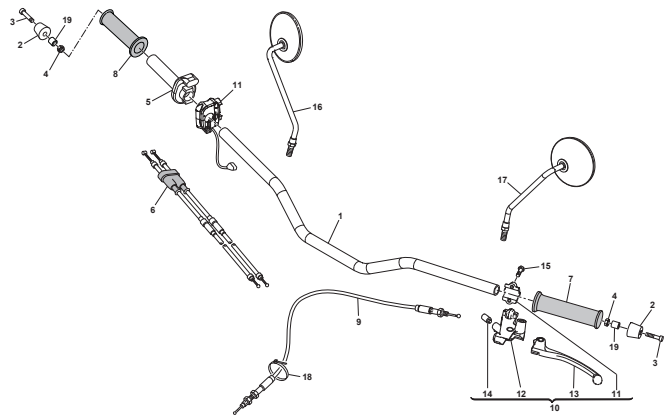

Pagina - Page - Page - Seite - Paja

56

Tavola - Drawing - Table - Bild - Tabla

22

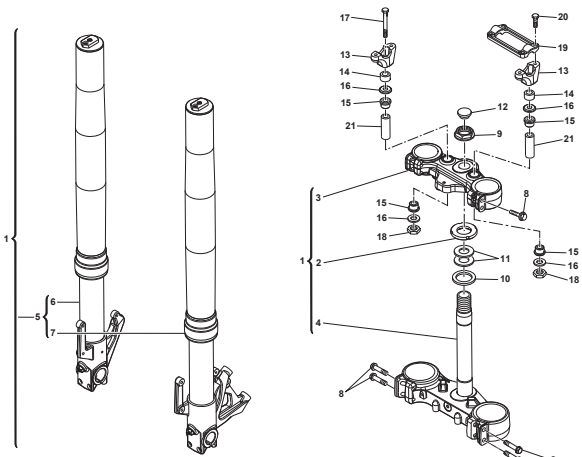

Pagina - Page - Page - Seite - Paja

58

Tavola - Drawing - Table - Bild - Tabla

22A

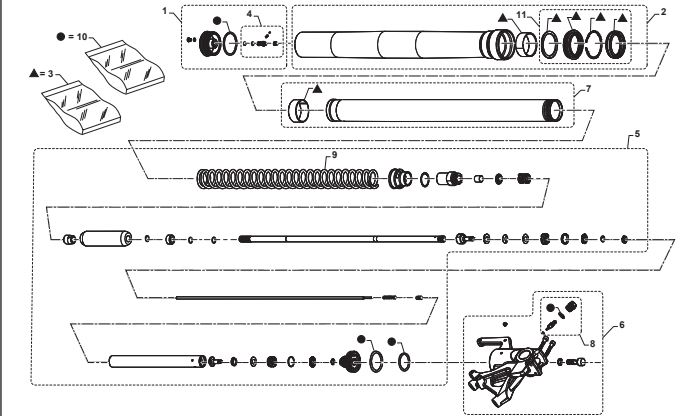

Pagina - Page - Page - Seite - Paja

60

Tavola - Drawing - Table - Bild - Tabla

22B

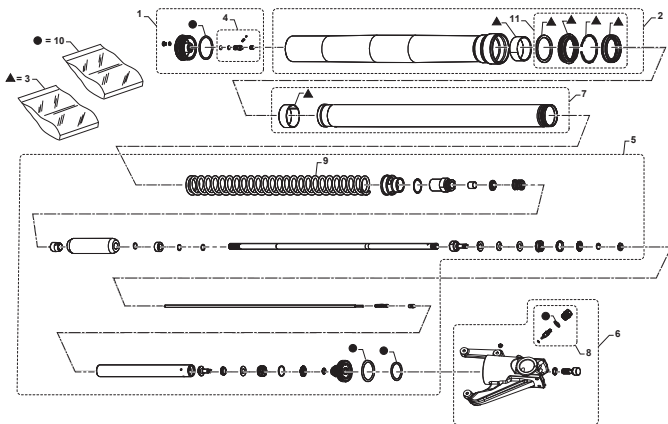

Pagina - Page - Page - Seite - Paja

62

Tavola - Drawing - Table - Bild - Tabla

23

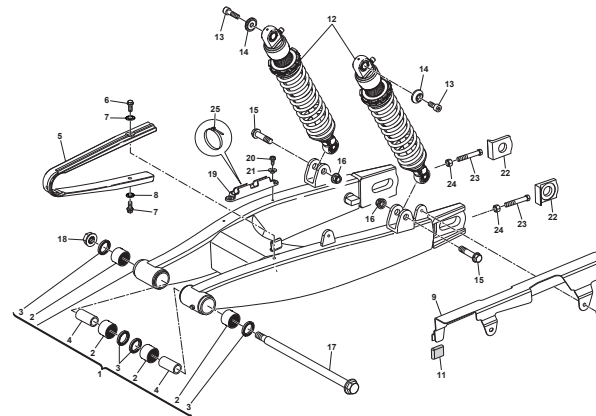

Pagina - Page - Page - Seite - Paja

64

Tavola - Drawing - Table - Bild - Tabla

24

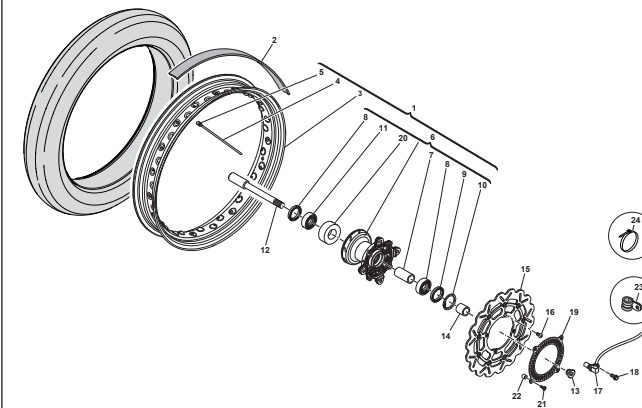

Pagina - Page - Page - Seite - Paja

66

Tavola - Drawing - Table - Bild - Tabla

25

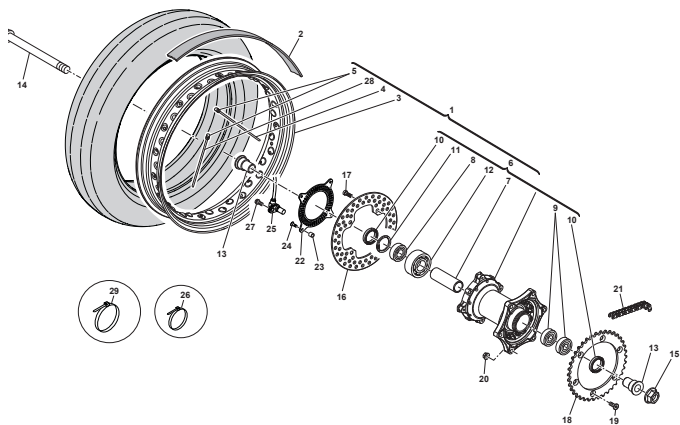

Pagina - Page - Page - Seite - Paja

68

Tavola - Drawing - Table - Bild - Tabla

26

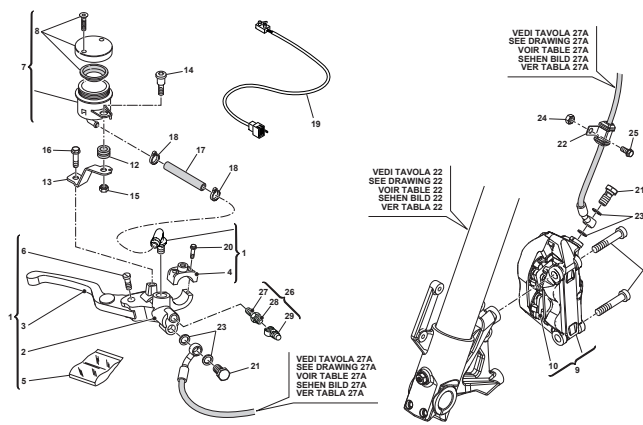

Pagina - Page - Page - Seite - Paja

70

Tavola - Drawing - Table - Bild - Tabla

27

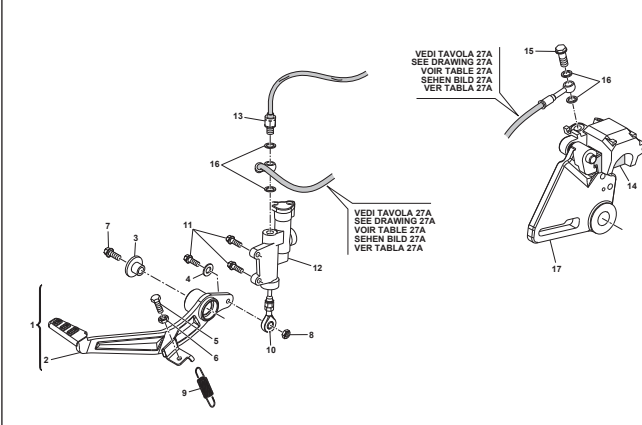

Pagina - Page - Page - Seite - Paja

72

Tavola - Drawing - Table - Bild - Tabla

27A

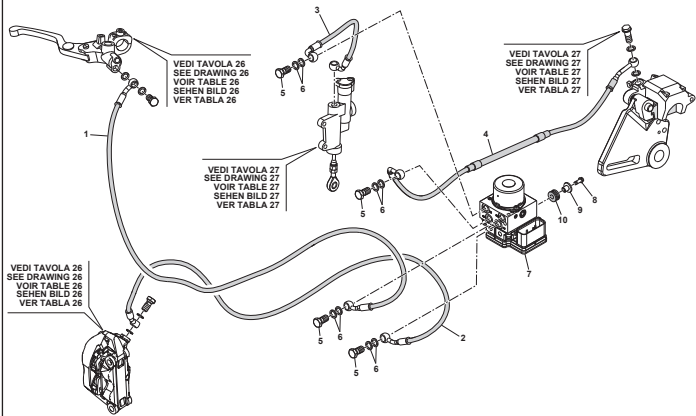

Pagina - Page - Page - Seite - Paja

74

Tavola - Drawing - Table - Bild - Tabla

28

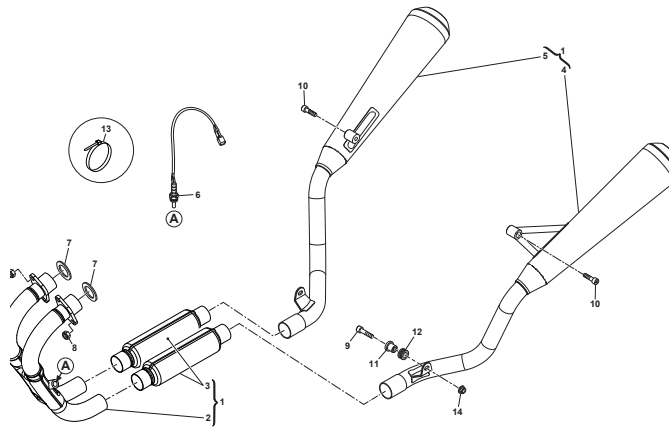

Pagina - Page - Page - Seite - Paja

76

Tavola - Drawing - Table - Bild - Tabla

29

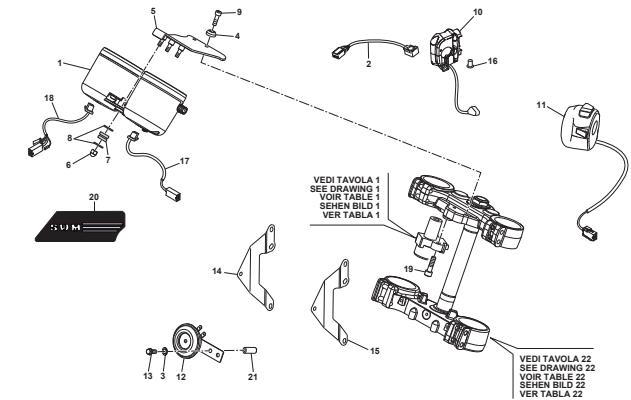

Pagina - Page - Page - Seite - Paja

78

Tavola - Drawing - Table - Bild - Tabla

30

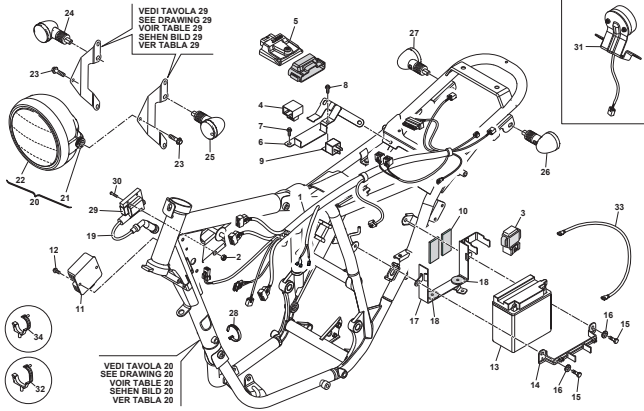

Pagina - Page - Page - Seite - Paja

80

Tavola - Drawing - Table - Bild - Tabla

31

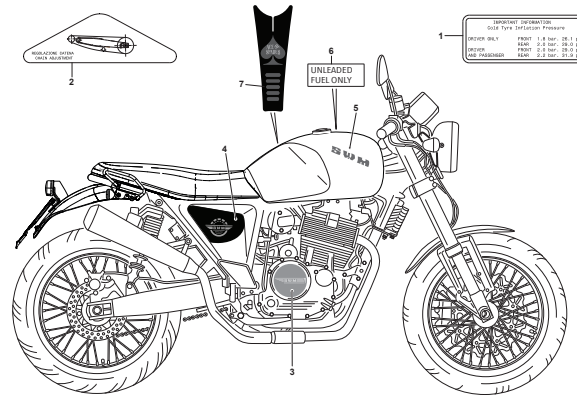

Pagina - Page - Page - Seite - Paja

84



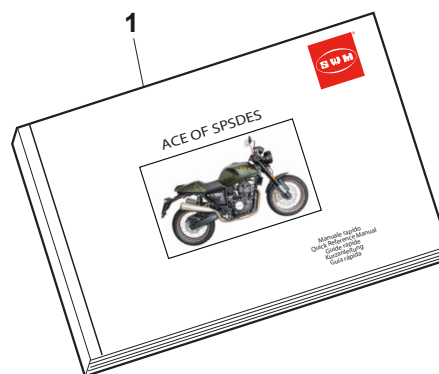
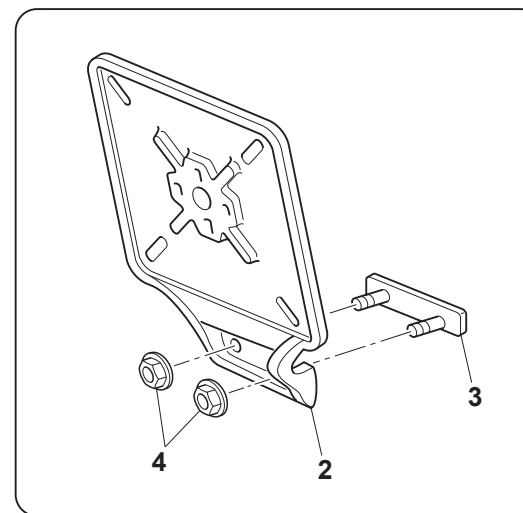
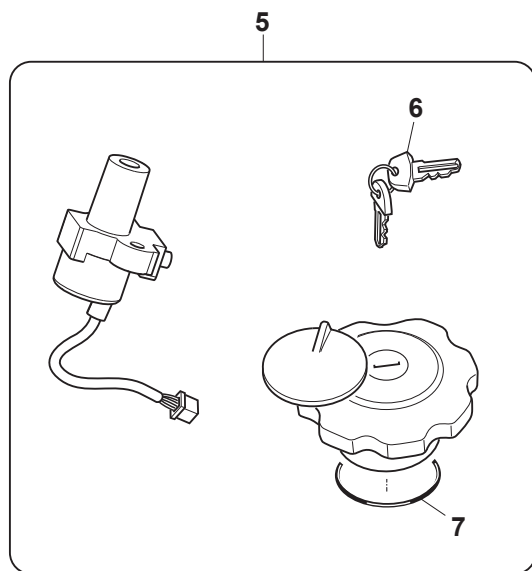

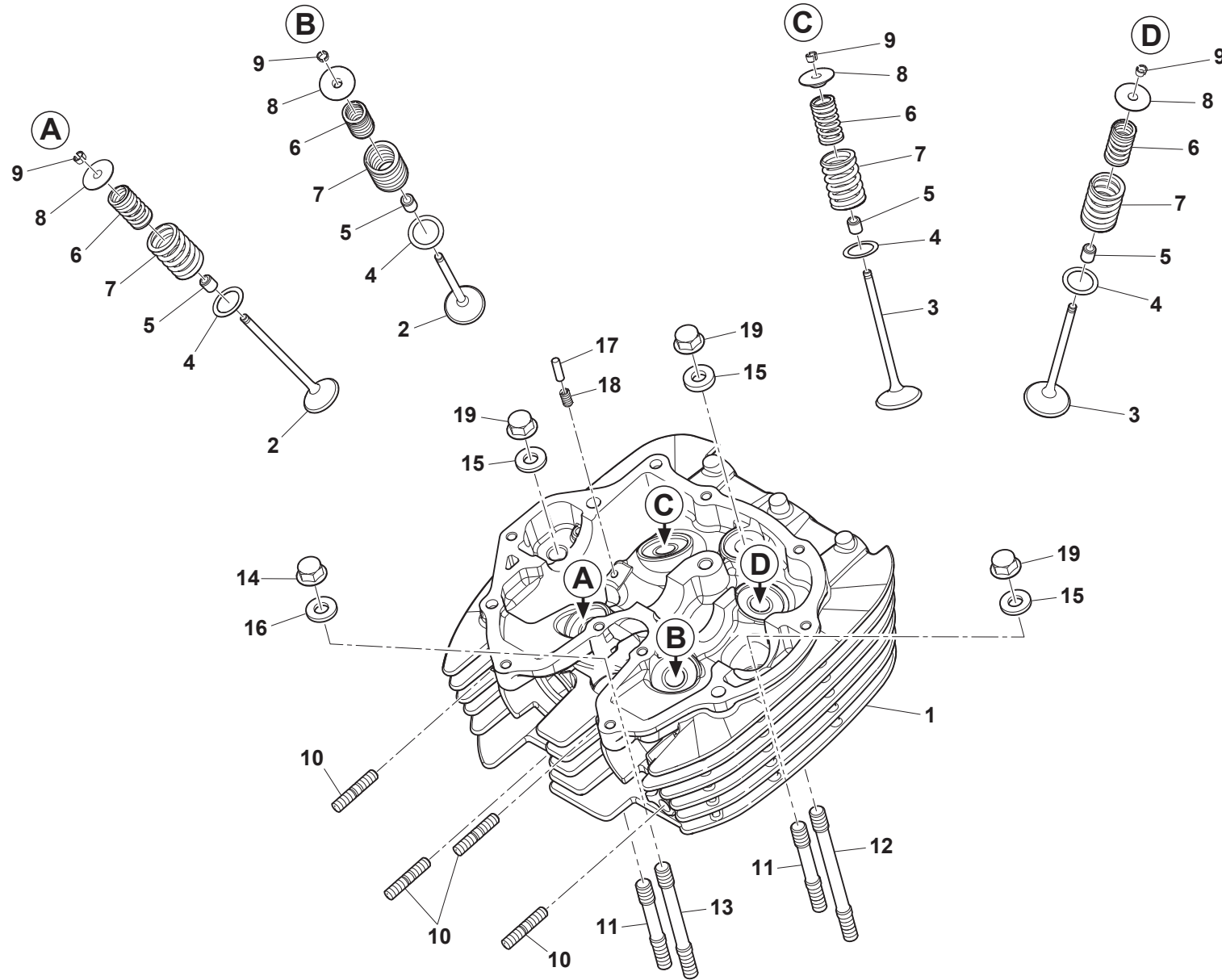



ACE OF SPADES

TESTA CILINDRO - CYLINDER HEAD CULASSE - ZYLINDERKOPF CULATA

TAVOLA
DRAWING
TABLE
BILD
TABLA

3

Note Notes Marke Notas	Pos. No. Index Pos.	N. Cod. Code No. Nr. Code Code Nr N. Cod.	Q.tà Q.ty Q.te M.ge C.ad	DENOMINAZIONE	NAME	DESIGNATION	BESHREIBUNG	DENOMINACION
	1	22011001	1	TESTA MOTORE COMPLETA	ENGINE HEAD ASSY	CULASSE COMPLETE	MOTORKOPF KOMPLETT	CULATA COMPLETA
	2	22020044	2	VALVOLA DI SCARICO	EXHAUST VALVE	SOUPAPE D'ECHAPPEMENT	AUSLASSVENTIL	VÁLVULA DE ESCAPE
	3	22020043	2	VALVOLA DI ASPIRAZIONE	INTAKE VALVE	SOUPAPE D'ADMISSION	EINLASSVENTIL	VÁLVULA DE ADMISIÓN
	4	72040365	4	ROSETTA PER MOLLA Ø18.7x26.3x1	OUTER SPRING WASHER 18.7x26.3x1	RONDELLE Ø18.7x26.3x1	UNTERLEGSSCHEIBE Ø18.7x26.3x1	ARANDELA Ø18.7x26.3x1
	5	72110026	4	TENUTA VALVOLE	VALVE SEALING	D'ETANCHEITE SOUPAPES	VENTILDICHTUNGS	ESTANQUEIDAD VALVULAS Ø5
	6	72120082	4	MOLLA INTERNA VALVOLA	INTERNAL VALVE SPRING	RESSORT INTERIEUR	INTERNE FEDER	MUELLE INTERNO
	7	72120083	4	MOLLA ESTERNA VALVOLA	EXTERNAL VALVE SPRING	RESSORT EXTERIEUR	EXTERNE FEDER	MUELLE EXTERNO
	8	22030003	4	SCODELLINO	RETAINER	RONDELLE À RESSORT	FEDERTELLER	ASIENTO
	9	22040003	4	SEMICONO	COLLET	DEMI-CONE	KEGELHÄLFTE	SEMICONO
	10	72011809	4	VITE M8x41	BOLT M8x41	VIS M8x41	SCHRAUBE M8x41	TORNILLO M8x41
	11	72011372	2	PRIGIONIERO M10x86	STUD BOLT M10x86	PRISONNIER M10x86	STIFTSCHRAUBE M10x86	PRISIONERO M10x86
	12	72011373	1	PRIGIONIERO M10x118	STUD BOLT M10x118	PRISONNIER M10x118	STIFTSCHRAUBE M10x118	PRISIONERO M10x118
	13	72011376	1	PRIGIONIERO M10x99	STUD BOLT M10x99	PRISONNIER M10x99	STIFTSCHRAUBE M10x99	PRISIONERO M10x99
	14	72020359	1	TAPPO A VITE M10x1.25	CAP NUT M10x1.25	BOUCHON M10x1.25	STOPFEN M10x1.25	TAPON M10x1.25
	15	72040369	3	ROSETTA Ø10.3x20.8x3	WASHER Ø10.3x20.8x3	RONDELLE Ø10.3x20.8x3	UNTERLEGSSCHEIBE Ø10.3x20.8x3	ARANDELA Ø10.3x20.8x3
	16	72040370	1	ROSETTA Ø10.3x25x4	WASHER Ø10.3x25x4	RONDELLE Ø10.3x25x4	UNTERLEGSSCHEIBE Ø10.3x25x4	ARANDELA Ø10.3x25x4
	17	72060088	1	PERNO	PIN	AXE	BOLZEN	EJE
	18	72120086	1	MOLLA LEVA DECOMPRESSORE	DECOMPRESSION LEVER SPRING	RESSORT	FEDER	MUELLE
	19	72020024	3	TAPPO A VITE M10x1,25	CAP NUT M10x1,25	BOUCHON M10x1,25	DECKEL M10x1,25	TAPON M10x1,25

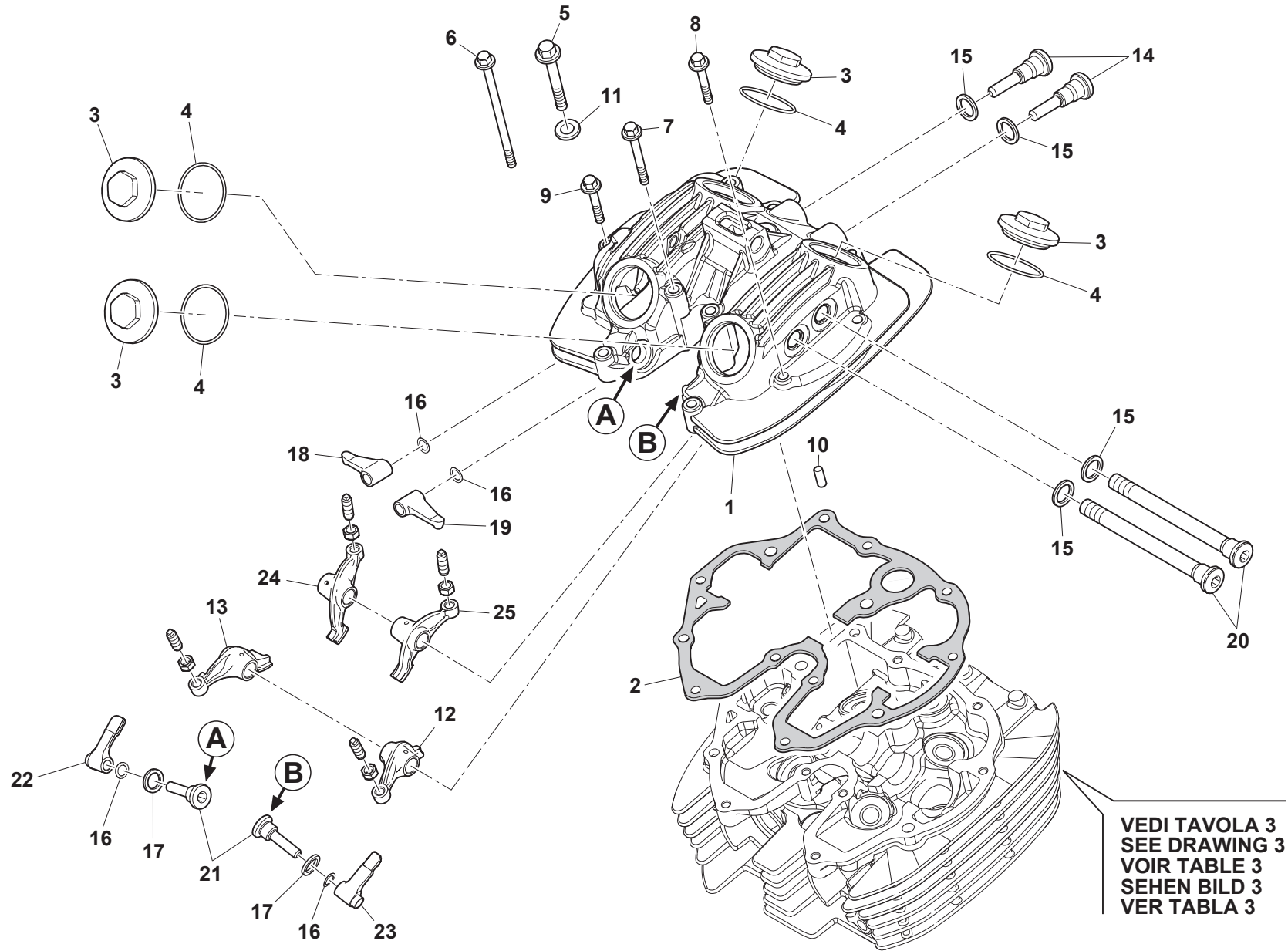



ACE OF SPADES

COPERCHIO VALVOLE - VALVE COVER COUVERCLE CULASSE - ZYLINDERKOPFDECKEL TAPA CULATA

TAVOLA
DRAWING
TABLE
BILD
TABLA

4

Note Notes Marke Notas	Pos. No. Index Pos.	N. Cod. Code No. Nr. Code Code Nr N. Cod.	Q.tà Q.ty Q.te M.ge C.ad	DENOMINAZIONE	NAME	DESIGNATION	BESHREIBUNG	DENOMINACION
	1	22150272	1	COPERCHIO TESTA MOTORE	CYLINDER HEAD COVER	COUVERCLE CULASSE	ZYLINDERKOPFDECKEL	TAPA CULATA
	2	72130392	1	GUARNIZIONE COPERCHIO TESTA	HEAD COVER GASKET	JOINT COUVERCLE CULASSE	DICHTUNG ZYLINDERKOPFDECKEL	JUNTA TAPA CULATA
	3	22140006	4	TAPPO VALVOLA	VALVE PLUG	BOUCHON	STOPFEN	TAPON
	4	72150013	4	ANELLO OR	O-RING	JOINT TORIQUE	O-RING	JUNTA TORICA
	5	72011374	1	VITE M8x70	BOLT M8x70	VIS M8x70	SCHRAUBE M8x70	TORNILLO M8x70
	6	72011917	3	VITE M6x119	BOLT M6x119	VIS M6x119	SCHRAUBE M6x119	TORNILLO M6x119
	7	72010392	2	VITE M6x65	BOLT M6x65	VIS M6x65	SCHRAUBE M6x65	TORNILLO M6x65
	8	72010389	1	VITE M6x40	BOLT M6x40	VIS M6x40	SCHRAUBE M6x40	TORNILLO M6x40
	9	72010169	6	VITE M6x35	BOLT M6x35	VIS M6x35	SCHRAUBE M6x35	TORNILLO M6x35
	10	72060012	2	SPINA Ø8x14	DOWEL PIN Ø8x14	GOUPILLE Ø8x14	STIFT Ø8x14	CLAVIJA Ø8x14
	11	72040156	1	ROSETTA IN RAME Ø8.5x18x2	COPPER WASHER Ø8.5x18x2	RONDELLE Ø8.5x18x2	UNTERLEGSCHEIBE Ø8.5x18x2	ARANDELA Ø8.5x18x2
	12	22050019	1	BILANCIERE	ROCKER ARM	CULBUTEUR	UMLENK-HEBEL	BALANCÍN
	13	22050020	1	BILANCIERE	ROCKER ARM	CULBUTEUR	UMLENK-HEBEL	BALANCÍN
	14	22070014	2	ALBERO BILANCIERE	ROCKER ARM SHAFT	ARBRE	WELLE	ARBOL
	15	72040364	4	ROSETTA IN RAME Ø14.2x20x1.5	COPPER WASHER Ø14.2x20x1.5	RONDELLE Ø14.2x20x1.5	UNTERLEGSCHEIBE Ø14.2x20x1.5	ARANDELA Ø14.2x20x1.5
	16	73131480	4	ROSETTA Ø8.2x12x0.3	WASHER Ø8.2x12x0.3	RONDELLE Ø8.2x12x0.3	UNTERLEGSCHEIBE Ø8.2x12x0.3	ARANDELA Ø8.2x12x0.3
	17	72040363	2	ROSETTA IN RAME Ø12.2x18.5x2	COPPER WASHER Ø12.2x18.5x2	RONDELLE Ø12.2x18.5x2	UNTERLEGSCHEIBE Ø12.2x18.5x2	ARANDELA Ø12.2x18.5x2
	18	22050018	1	BILANCIERE	ROCKER ARM	CULBUTEUR	UMLENK-HEBEL	BALANCÍN
	19	22050018	1	BILANCIERE	ROCKER ARM	CULBUTEUR	UMLENK-HEBEL	BALANCÍN
	20	22070015	2	ALBERO PRINCIPALE BILANCIERE M14x1.5	MAIN ROCKER ARM SHAFT M14x1.5	ARBRE M14x1.5	WELLE M14x1.5	ARBOL M14x1.5
	21	22070013	2	ALBERO BILANCIERE	ROCKER ARM SHAFT	ARBRE	WELLE	ARBOL
	22	22050016	1	BILANCIERE SINISTRO	ROCKER ARM L.H.	CULBUTEUR G.	UMLENK-HEBEL L.	BALANCÍN IZQ.
	23	22050017	1	BILANCIERE DESTRO	ROCKER ARM R.H.	CULBUTEUR D.	UMLENK-HEBEL R.	BALANCÍN DER.
	24	22050019	2	BILANCIERE	ROCKER ARM	CULBUTEUR	UMLENK-HEBEL	BALANCÍN
	25	22050020	1	BILANCIERE	ROCKER ARM	CULBUTEUR	UMLENK-HEBEL	BALANCÍN

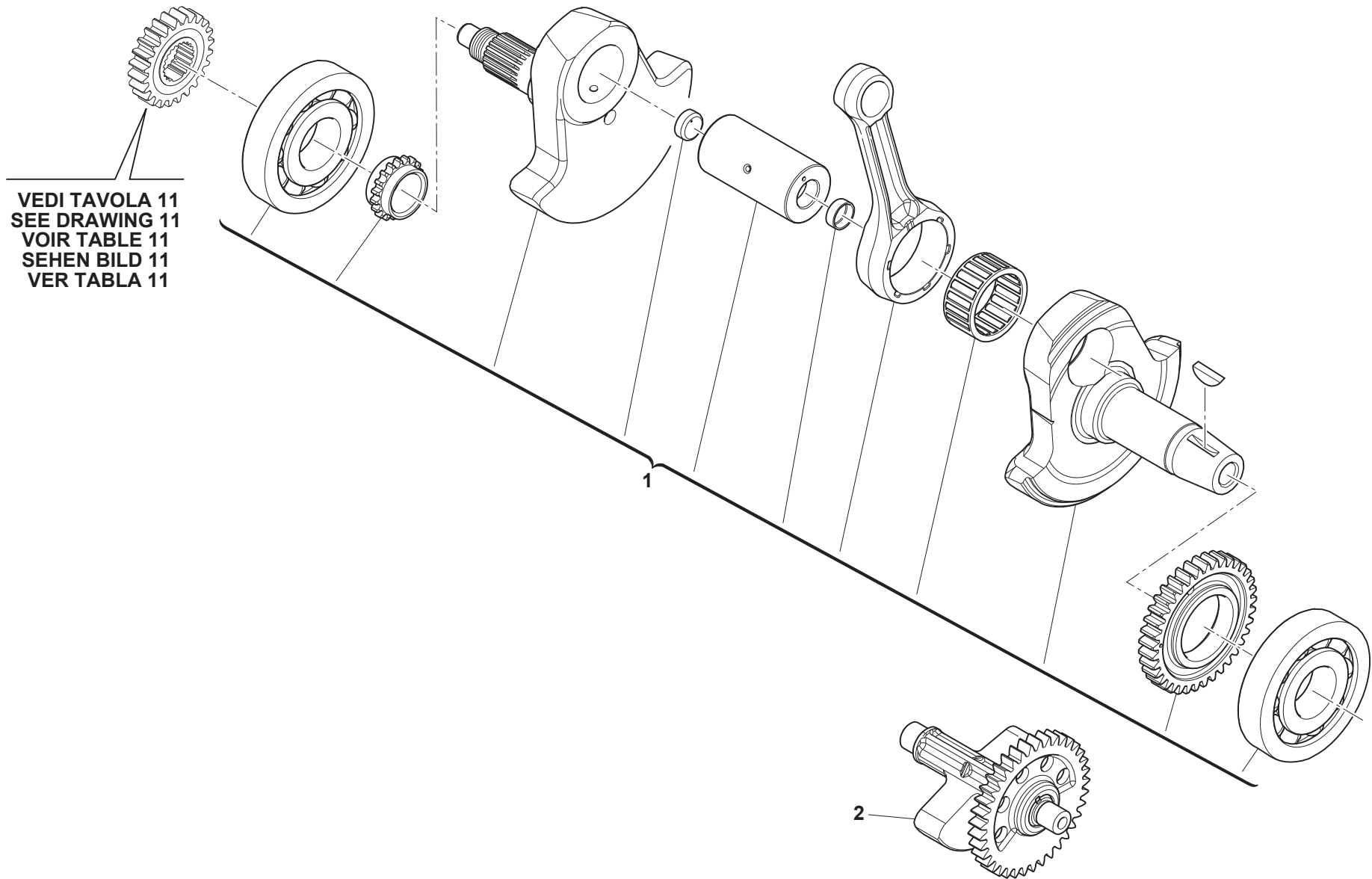

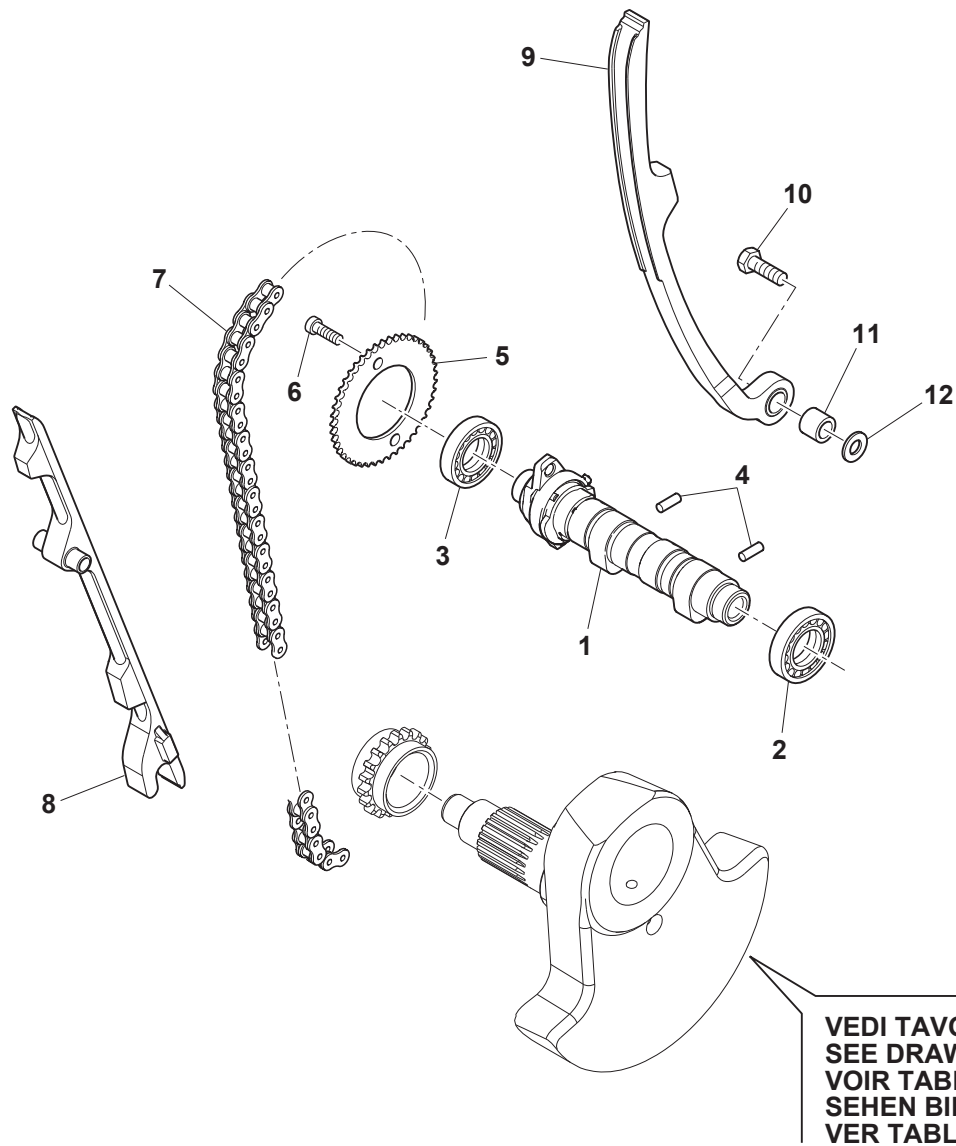

VEDI TAVOLA 2
SEE DRAWING 2
VOIR TABLE 2
SEHEN BILD 2
VER TABLA 2

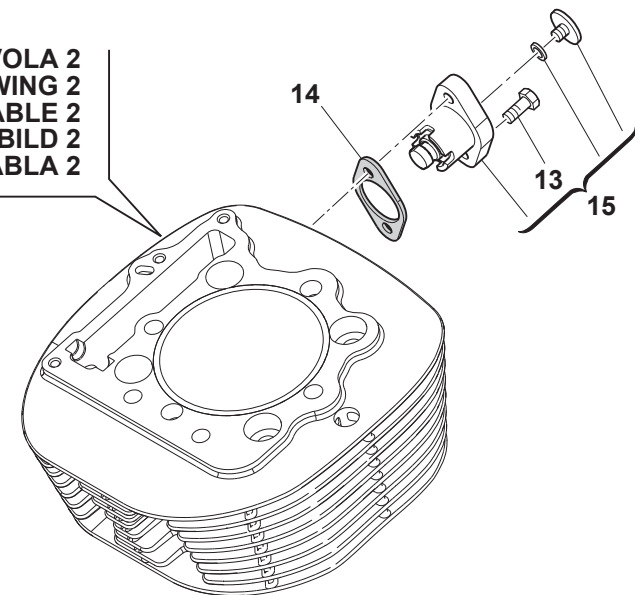

VEDI TAVOLA 5
SEE DRAWING 5
VOIR TABLE 5
SEHEN BILD 5
VER TABLA 5

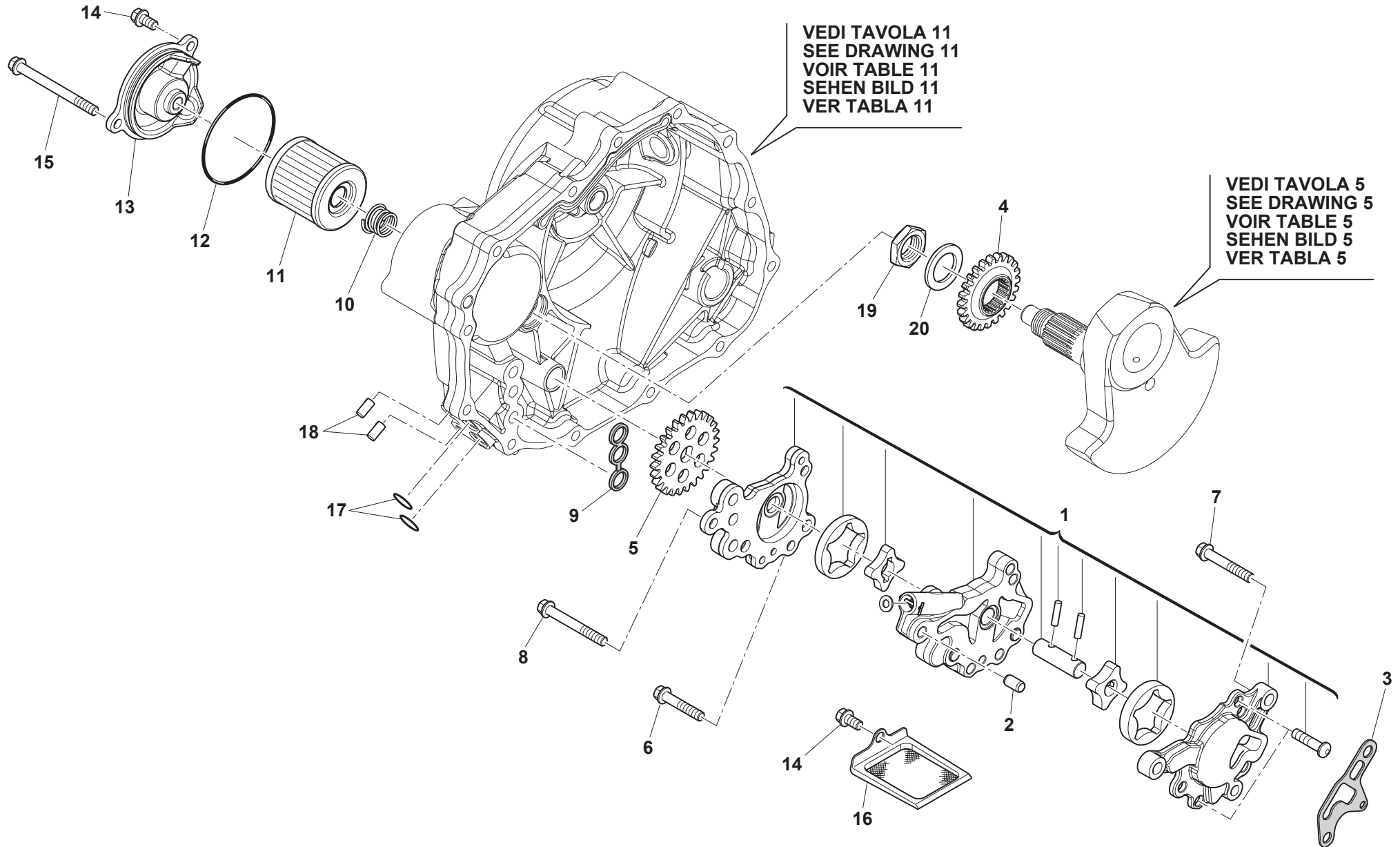

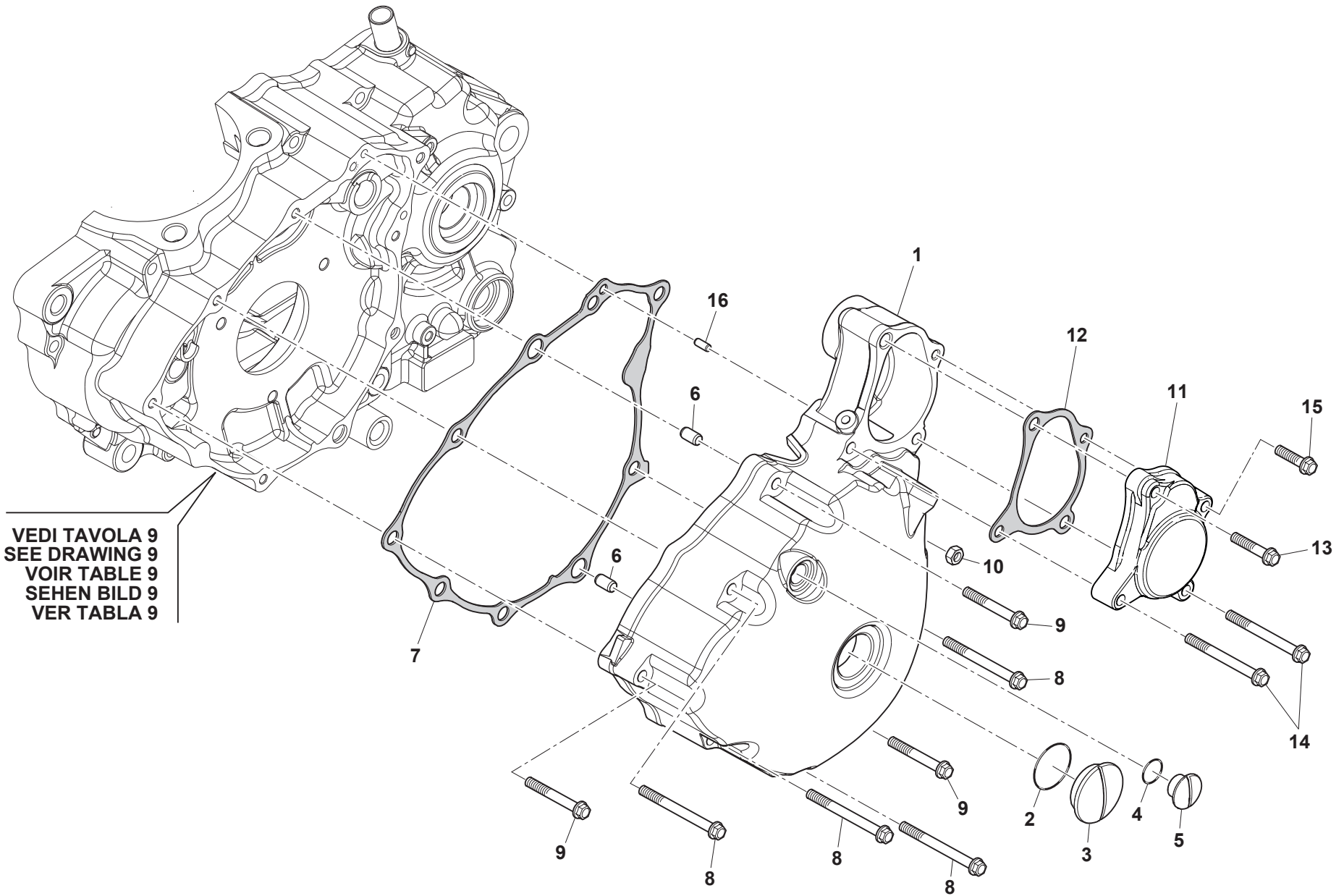

VEDI TAVOLA 9
SEE DRAWING 9
VOIR TABLE 9
SEHEN BILD 9
VER TABLA 9

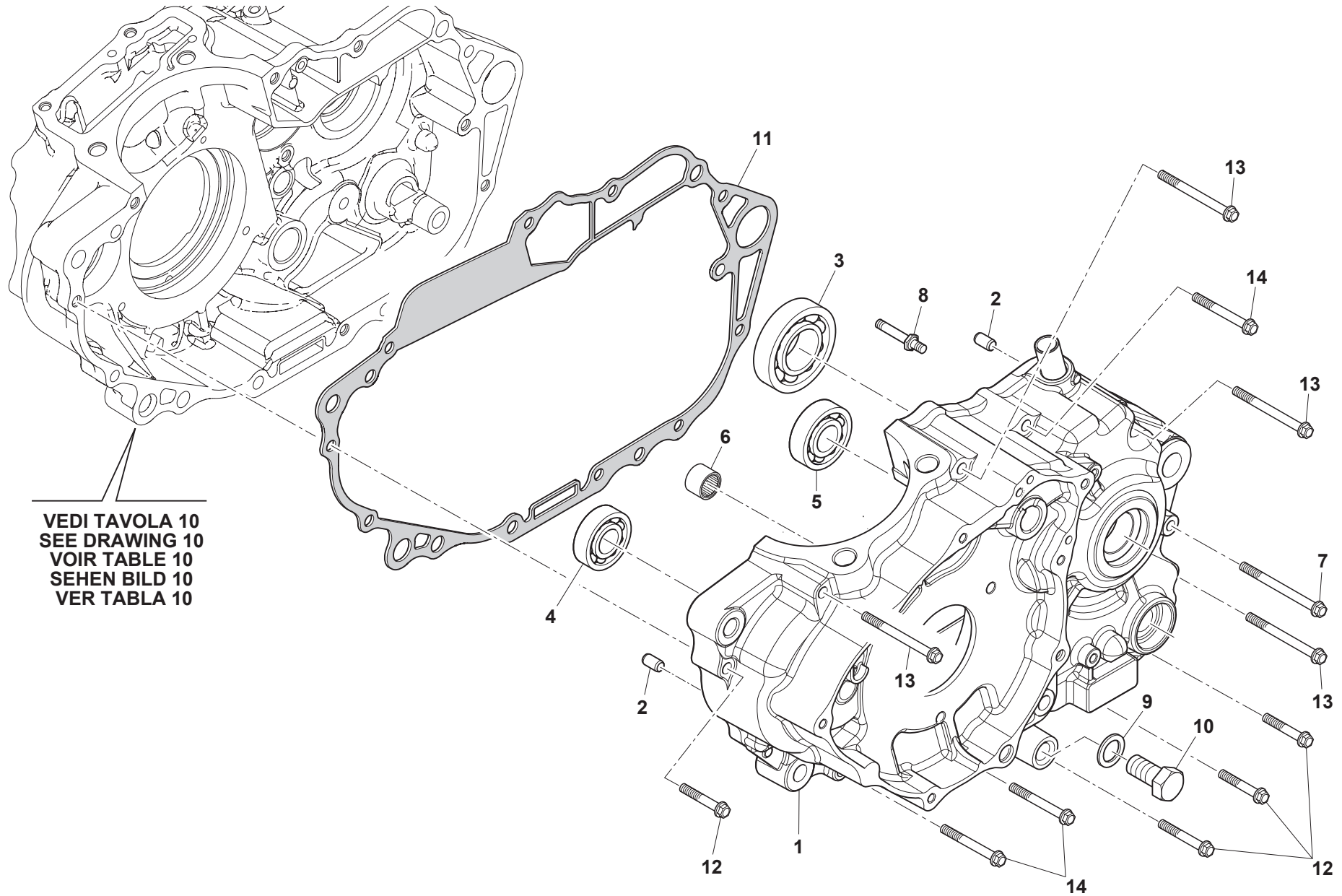

VEDI TAVOLA 10
SEE DRAWING 10
VOIR TABLE 10
SEHEN BILD 10
VER TABLA 10

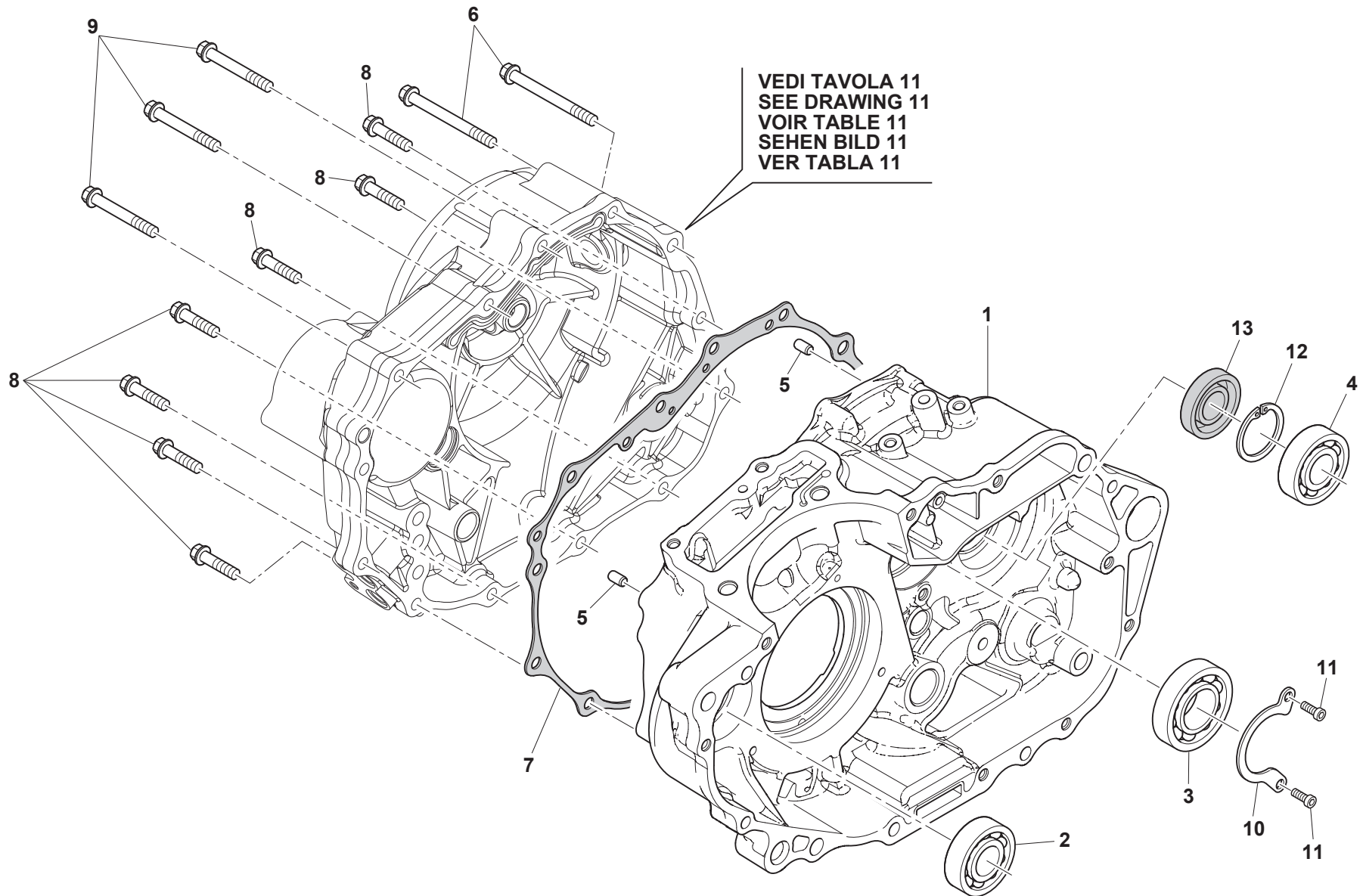



ACE OF SPADES

SEMICARTER DESTRO - RIGHT HALF CRANKCASE
CARTER DROIT - GEHAUSEDECKEL RECHTS
BANCADA DERECHO

TAVOLA
DRAWING
TABLE
BILD
TABLA

10

Note Notes Notes Marke Notas	Pos. No. Index Pos.	N. Cod. Code No. Nr. Code Code Nr N. Cod.	Q.tà Q.ty Q.te M.ge C.ad	DENOMINAZIONE	NAME	DESIGNATION	BESHREIBUNG	DENOMINACION
	1	12010623	1	CARTER DESTRO	RIGHT CRANKCASE	CARTER D.	GEHAUSE R.	CARTER DER.
	2	70090192	1	CUSCINETTO 6302/C3	BEARING 6302/C3	ROULEMENT 6302/C3	LAGER 6302/C3	COJINETE 6302/C3
	3	70090196	1	CUSCINETTO 62/22	BEARING 62/22	ROULEMENT 62/22	LAGER 62/22	COJINETE 62/22
	4	70090197	1	CUSCINETTO 60/22/18	BEARING 60/22/18	ROULEMENT 60/22/18	LAGER 60/22/18	COJINETE 60/22/18
	5	72060012	2	BUSSOLA Ø10x14	DOWEL PIN Ø10x14	DOUILLE Ø10x14	BUCHSE Ø10x14	CASQUILLO Ø10x14
	6	72010392	2	VITE M6x65	BOLT M6x65	VIS M6x65	SCHRAUBE M6x65	TORNILLO M6x65
	7	72130607	1	GUARNIZIONE COPERCHIO FRIZIONE	GASKET	JOINT	DICHTUNG	JUNTA
	8	72010387	7	VITE M6x28	BOLT M6x28	VIS M6x28	SCHRAUBE M6x28	TORNILLO M6x28
	9	72010390	3	VITE M6x45	BOLT M6x45	VIS M6x45	SCHRAUBE M6x45	TORNILLO M6x45
	10	73131479	1	PIASTRA ALBERO PRIMARIO	PLATE INPUT SHAFT	PLAQUE ARBRE PRIMAIRE	PLATTE	PLACA ARBOL PRIMARIO
	11	72011368	2	VITE	BOLT	VIS	SCHRAUBE	TORNILLO
	12	72080066	1	ANELLO DI TENUTA Ø24x35x5	SEALING RING Ø24x35x5	BAGUE D'ETANCHEITE Ø24x35x5	DICHTUNGSRING Ø24x35x5	ANILLO DE ESTANQUEIDAD Ø24x35x5
	13	72110096	1	ANELLO DI TENUTA Ø18x34x5	SEALING RING Ø18x34x5	BAGUE D'ETANCHEITE Ø18x34x5	DICHTUNGSRING Ø18x34x5	ANILLO DE ESTANQUEIDAD Ø18x34x5

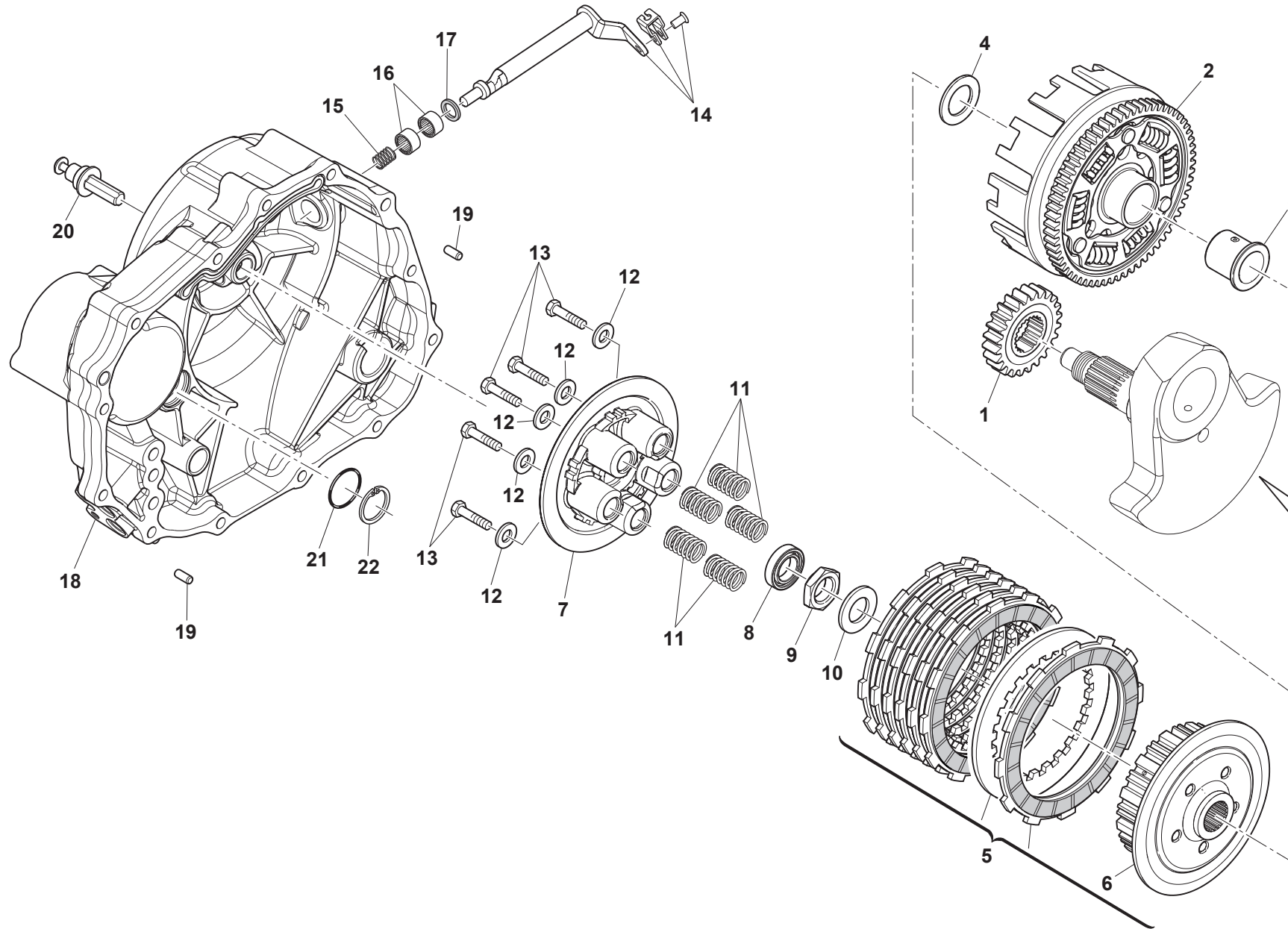

VEDI TAVOLA 5
SEE DRAWING 5
VOIR TABLE 5
SEHEN BILD 5
VER TABLA 5



ACE OF SPADES

FRIZIONE - CLUTCH EMBAYAGE - KUPPLUNG EMBRAGUE

TAVOLA
DRAWING
TABLE
BILD
TABLA

11

Note Notes Marke Notas	Pos. No. Index Pos.	N. Cod. Code No. Nr. Code Code Nr N. Cod.	Q.tà Q.ty Q.te M.ge C.ad	DENOMINAZIONE	NAME	DESIGNATION	BESHREIBUNG	DENOMINACION
	1	24020044	1	INGR. CONDUTTORE PRIMARIA	PRIMARY DRIVE GEAR	ENGRENAGE CONDUCTEUR	ANTRIEBSZAHNRAD	ENGRANAJE CONDUCTOR
	2	24120157	1	INGR. CONDOTTO TRASM. PRIMARIA	DRIVEN GEAR, ASSY	ENGRENAGE CONDUIT	ANGETRIEBENES ZAHNRAD	ENGRANAJE CONDUCTIDO
	3	24070261	1	BUSSOLA FRIZIONE Ø22x28x29.3	CLUTCH BUSH Ø22x28x29.3	DOUILLE Ø22x28x29.3	BUCHSE Ø22x28x29.3	CASQUILLO Ø22x28x29.3
	4	24070204	1	ROSETTA Ø22x35x2	WASHER Ø22x35x2	RONDELLE Ø22x35x2	UNTERLEGSCHLEIBE Ø22x35x2	ARANDELA Ø22x35x2
	5	24120104	1	MOZZO PORTADISCHI	CLUTCH HUB	MOYEU PORTE-DISQUES	SCHEIBENNABE	CUBO PORTADISCOS
	6	24070251	1	MOZZO	HUB	MOYEU	NABE	CUBO
	7	24070256	1	PIATTO SPINGIDISCO	PUSH DISC PLATE	PLAQUE PRESSE-DISQUE	KUPPLUNGS-DRUCKPLATTE	PLATO PRESION DISCO
	8	24070205	1	CUSCINETTO 61903/P6	BEARING 61903/P6	ROULEMENT 61903/P6	LAGER 61903/P6	COJINETE 61903/P6
	9	24070163	1	DADO M18x1	NUT M18x1	ECROU M18x1	MUTTER M18x1	TUERCA M18x1
	10	72040222	1	RONDELLA	WASHER	RONDELLE	UNTERLEGSCHLEIBE	ARANDELA
	11	24070255	5	MOLLA PER FRIZIONE	CLUTCH SPRING	RESSORT POUR EMBRAYAGE	KUPPLUNGSFEDER	MUELLE PARA EMBRAGUE
	12	72040197	5	ROSETTA	WASHER	RONDELLE	UNTERLEGSCHLEIBE	ARANDELA
	13	72010097	5	VITE M6x35	SCREW M6x35	VIS M6x35	SCHRAUBE M6x35	TORNILLO M6x35
	14	24030031	1	LEVA DISINNESTO FRIZIONE	CLUTCH PUSH LEVER	LEVIER DEBRAYAGE	KUPPLUNGSAUSTRÜCKSTANGE	PALANCA DESACOPL.EMBRAGUE
	15	72120084	1	MOLLA LEVA DISINNESTO FRIZIONE	CLUTCH CONTROL ROD SPRING	RESSORT	FEDER	MUELLE
	16	70090016	2	CUSCINETTO HK1210	ROLLING NEEDLE HK1210	ROULEMENT HK1210	LAGER HK1210	COJINETE HK1210
	17	72110098	1	GUARNIZIONE	GASKET	JOINT	DICHTUNG	JUNTA
	18	13011908	1	COPERCHIO FRIZIONE	CLUTCH COVER	COUVERCLE D'EMBRAYAGE	KUPPLUNGSDECKEL	TAPA EMBRAGUE
	19	72060012	2	BUSSOLA Ø10x14	BUSHING Ø10x14	DOUILLE Ø10x14	BUCHSE Ø10x14	CASQUILLO Ø10x14
	20	24070295	1	ASTA DISINNESTO FRIZIONE	CLUTCH PUSHROD	TIGE DEBRAYAGE	KUPPLUNGSAUSTRÜCKSTANGE	VARILLA DESACOPAMIENTO EMBRAGUE
	21	72110097	1	ANELLO DI TENUTA Ø14x22x5	SEALING RING Ø14x22x5	BAGUE D'ETANCHEITE Ø14x22x5	DICHTUNGSRING Ø14x22x5	ANILLO DE ESTANQUEIDAD Ø14x22x5
	22	72080066	1	ANELLO DI FERMO INTERNO	INNER RETAINING RING	BAGUE D'ARRET	SICHERUNGSRING	ANILLO DE RETENCION

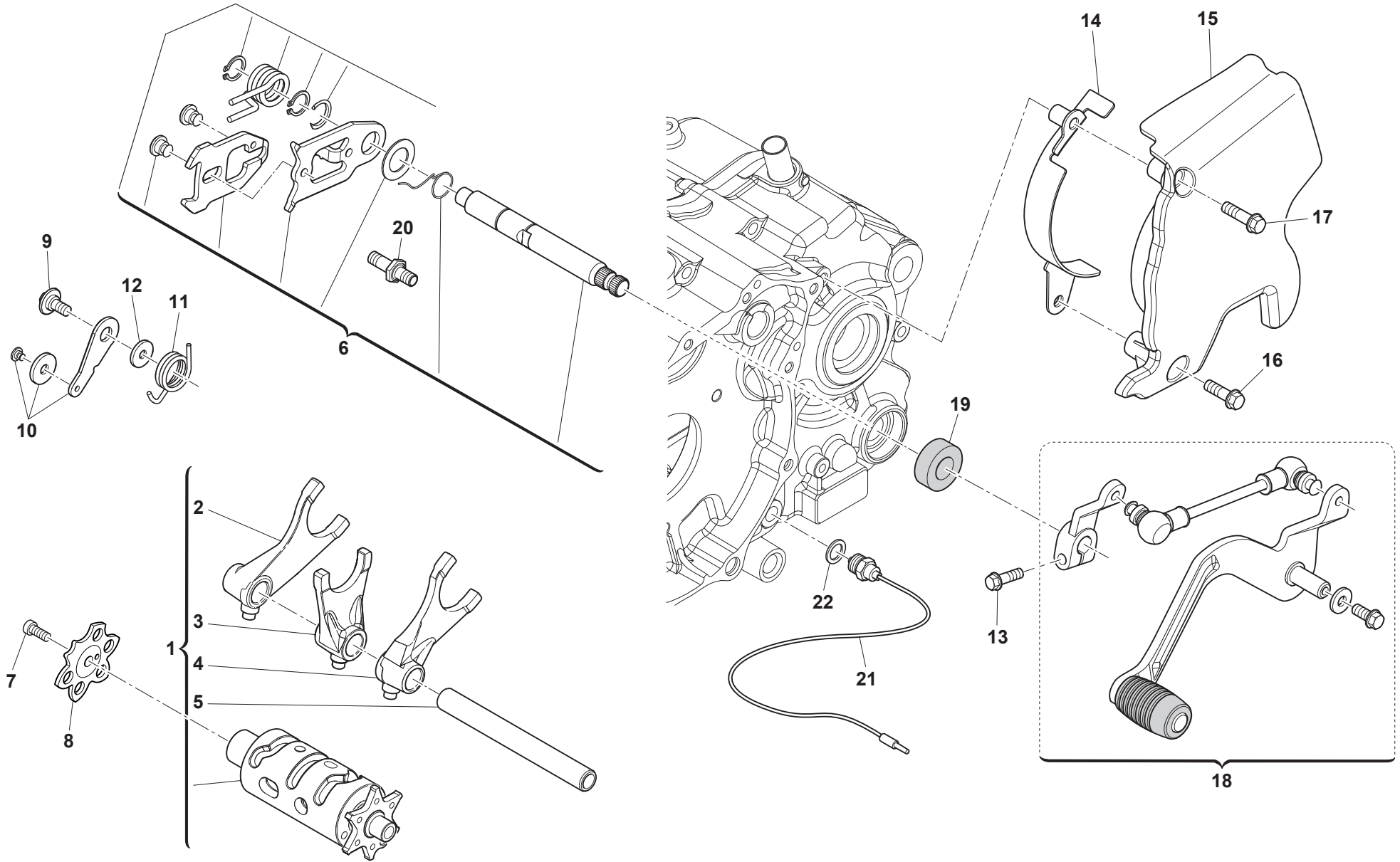



ACE OF SPADES

COMANDO CAMBIO - GEARSHIFT MECHANISM COMMANDE DE VITESSE - GANGSCHALTUNG MANDO CAMBIO

TAVOLA
DRAWING
TABLE
BILD
TABLA

12

Note Notes Marke Notas	Pos. No. N. Index Pos.	N. Cod. Code No. Nr. Code Code Nr N. Cod.	Q.tà Q.ty Q.te M.ge C.ad	DENOMINAZIONE	NAME	DESIGNATION	BESHREIBUNG	DENOMINACION
	1	15050043	1	ASS. TAMBURO SELETTORE MARCE	GEAR SELECTOR DRUM, ASSY	TAMBOUR SELECTEUR DE VITESSES COMPL.	SCHALTWALZE	TAMBOR SELECTOR MARCHAS
	2	15140017	1	FORCELLA CAMBIO (1ª)	GEARBOX FORK (1ST)	FOURCHE BOÎTE DE VITESSES (1ERE)	SCHALTGABEL 1.	HORQUILLA CAMBIO (1ª)
	3	15140018	1	FORCELLA CAMBIO (2ª)	GEARBOX FORK (2ND)	FOURCHE BOÎTE DE VITESSES (2EME)	SCHALTGABEL 2.	HORQUILLA CAMBIO (2ª)
	4	15140019	1	FORCELLA CAMBIO (3ª)	GEARBOX FORK (3RD)	FOURCHE BOÎTE DE VITESSES (3EME)	SCHALTGABEL 3.	HORQUILLA CAMBIO (3ª)
	5	15140020	1	PERNO FORCHETTE	AXES, FORKS	AXE FOURCHE	BOLZEN	EJE HORQUILLA
	6	15070043	1	SELETTORE CAMBIO	GEAR SHIFT SPINDLE, ASSY	SELECTEUR COMPL.	ZUSAMMENBAU SCHALTWALZE	CONJUNTO SELECTOR
	7	72011370	1	VITE PIASTRA FORCELLA INNESTO M6x20	BOLT, GEAR SHIFT FORK PLATE M6x20	VIS M6x20	SCHRAUBE M6x20	TORNILLO M6x20
	8	M000P01435	1	ROCCHETTO SELETTORE	SELECTOR SPROCKET	PIGNON SELECTEUR	SPULE SCHALTWALZE	PINON SELECTOR
	9	72011366	1	VITE M6x16	SCREW M6x16	VIS M6x16	SCHRAUBE M6x16	TORNILLO M6x16
	10	15080015	1	PIASTRINA	PLATE	PLAQUETTE	PLÄTTCHEN	PLACA
	11	M000P01155	1	MOLLA	SPRING	RESSORT	FEDER	MUELLE
	12	72040167	1	RONDELLA	WASHER	RONDELLE	UNTERLEGSCHIEBE	ARANDELA
	13	Z00062728	1	VITE TEF M6x20	FLANGED EXAGON HEAD SCREW M6x20	VIS M6x20	SCHRAUBE M6x20	TORNILLO M6x20
	14	F000P00870	1	GUIDACATENA LATO PIGNONE	DRIVE CHAIN	GUIDE DE CHAÎNE	KETTENFÜHRUNG	GUÍA CADENA
	15	14021193	1	COPERCHIO PIGNONE CATENA	CHAIN SPROCKET COVER	COUVERCLE PIGNON CHAÎNE	DECKEL KETTENRITZEL	TAPA PINON CADENA
	16	Z00062730	1	VITE TEF M6x30	FLANGED EXAGON HEAD SCREW M6x30	VIS M6x30	SCHRAUBE M6x30	TORNILLO M6x30
	17	ZE0067545	1	VITE TEF M6x40	BOLT M6x40	VIS M6x40	SCHRAUBE M6x40	TORNILLO M6x40
	18	F000A01644	1	ASS. LEVA COMANDO CAMBIO	GEAR CONTROL LEVER ASSY	LEVIER DE COM. BOÎTE DE VITESSES COMPL.	ZSB. SCHALTHEBEL	CONJ. PALANCA MANDO CAMBIO
	19	72110009	1	ANELLO DI TENUTA OLIO Ø14x28x7	SEALING RING Ø14x28x7	BAGUE D'ETANCHEITE Ø14x28x7	DICHTUNGSRING Ø14x28x7	ANILLO DE ESTANQUEIDAD Ø14x28x7
	20	72011363	1	VITE SELETTORE CAMBIO M8x41	GEARSHIFT POSITIONING BOLT	VIS M8x41	SCHRAUBE M8x41	TORNILLO M8x41
	21	11040209	1	SENSORE FOLLE	NEUTRAL POSITION SWITCH	CAPTEUR POINT MORT	LEERLAUFSENSOR	SENSOR PUNTO MUERTO
	22	72040362	1	ROSETTA IN RAME	COPPER WASHER	RONDELLE	UNTERLEGSCHIEBE	ARANDELA

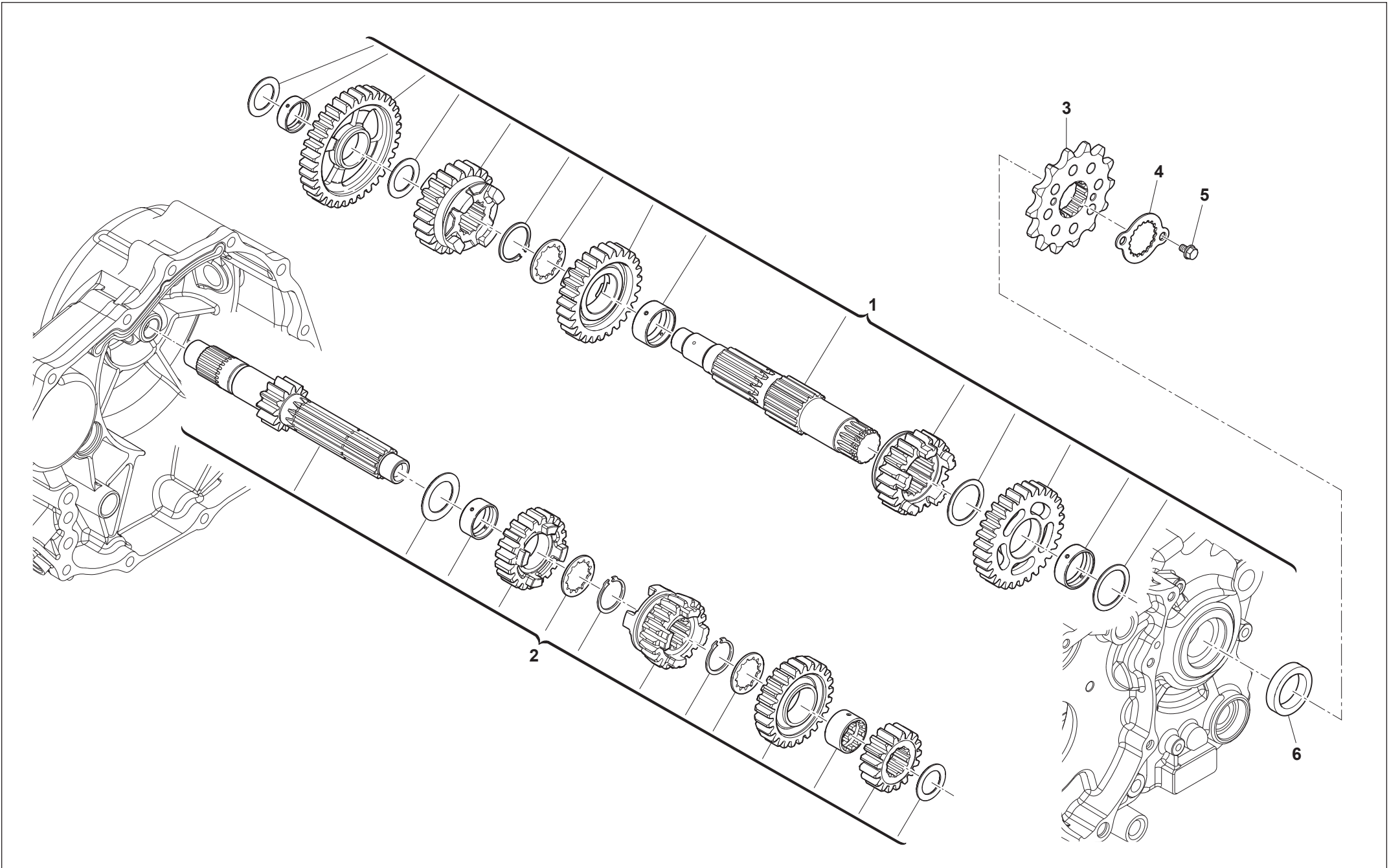

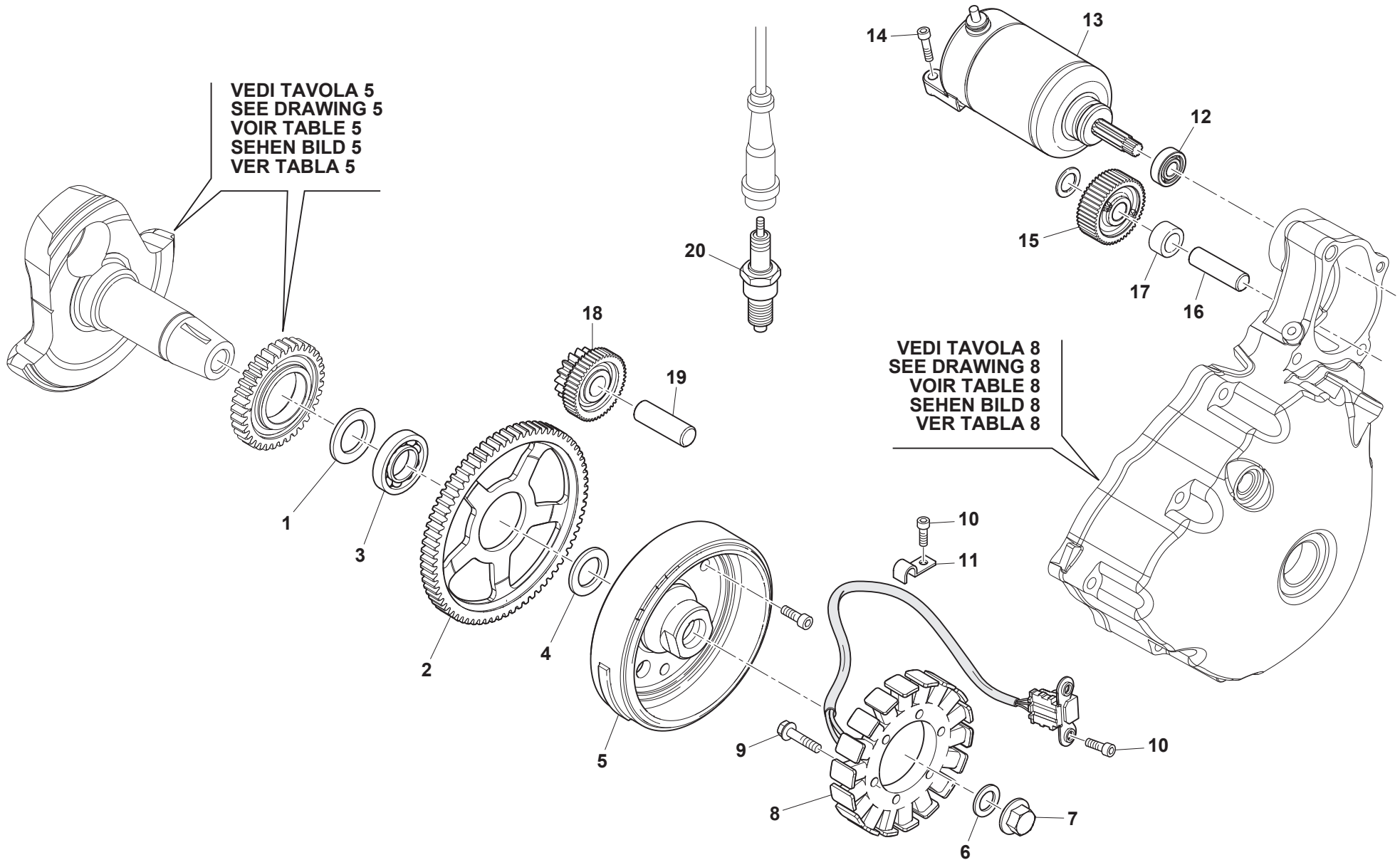

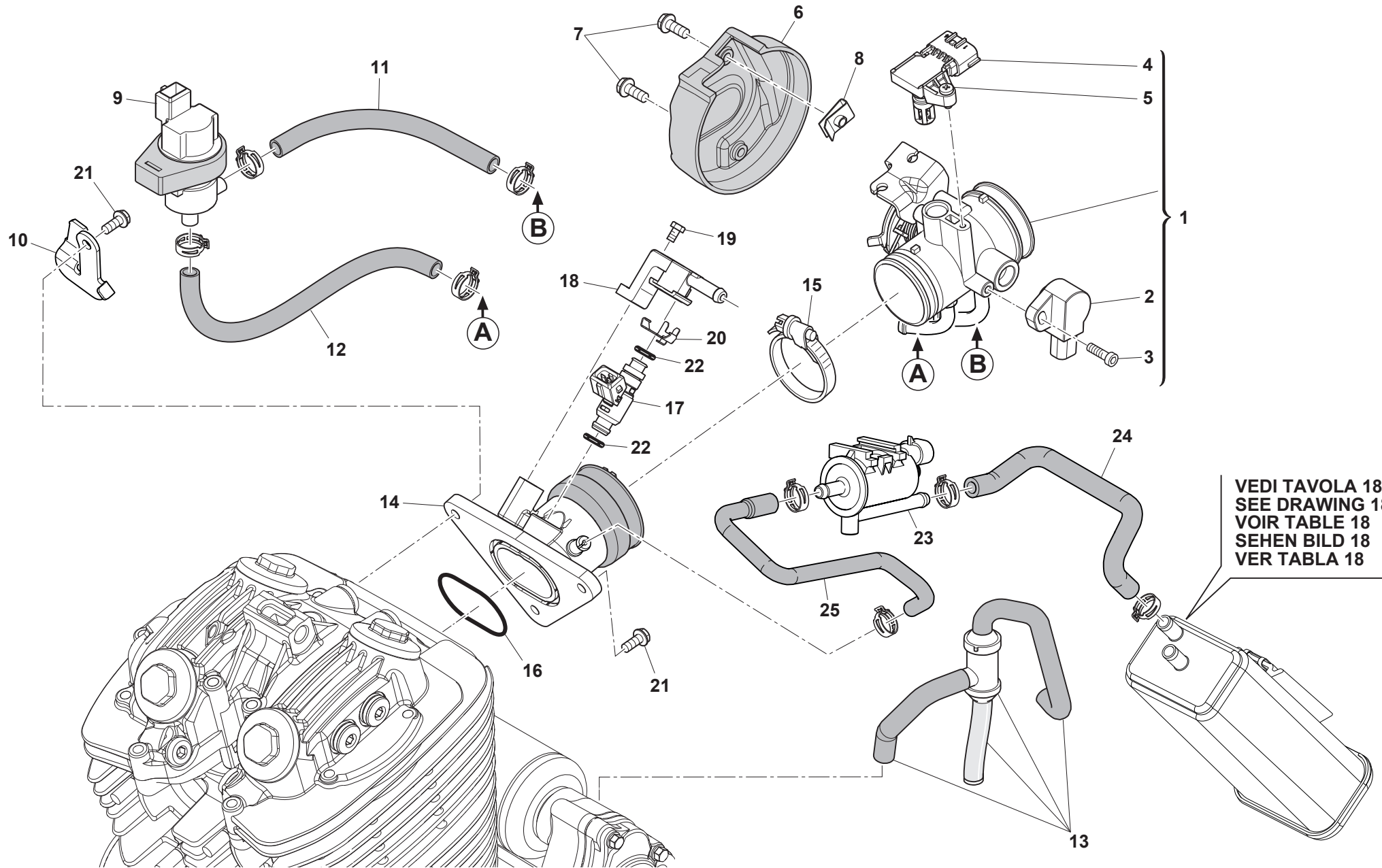

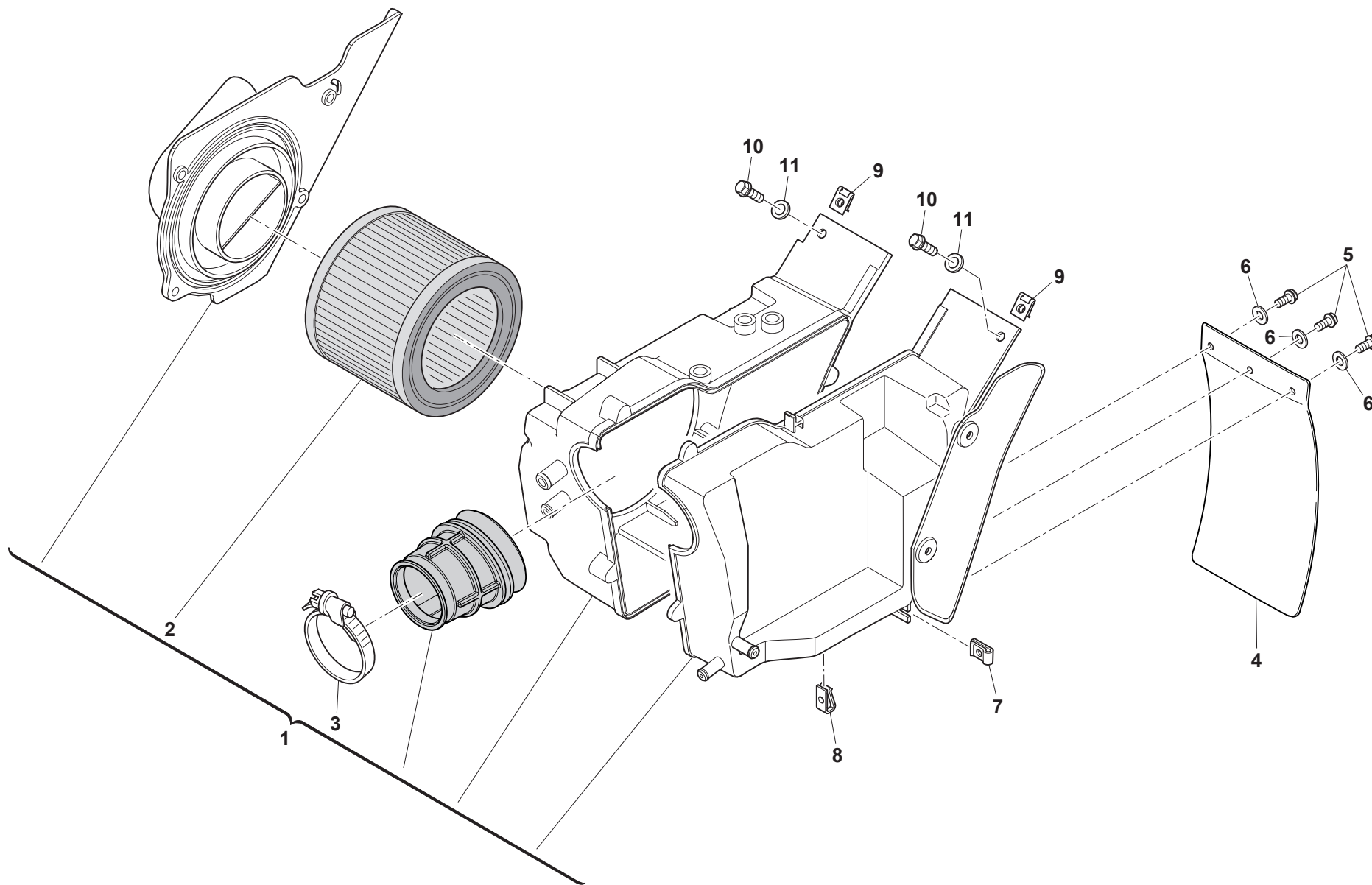

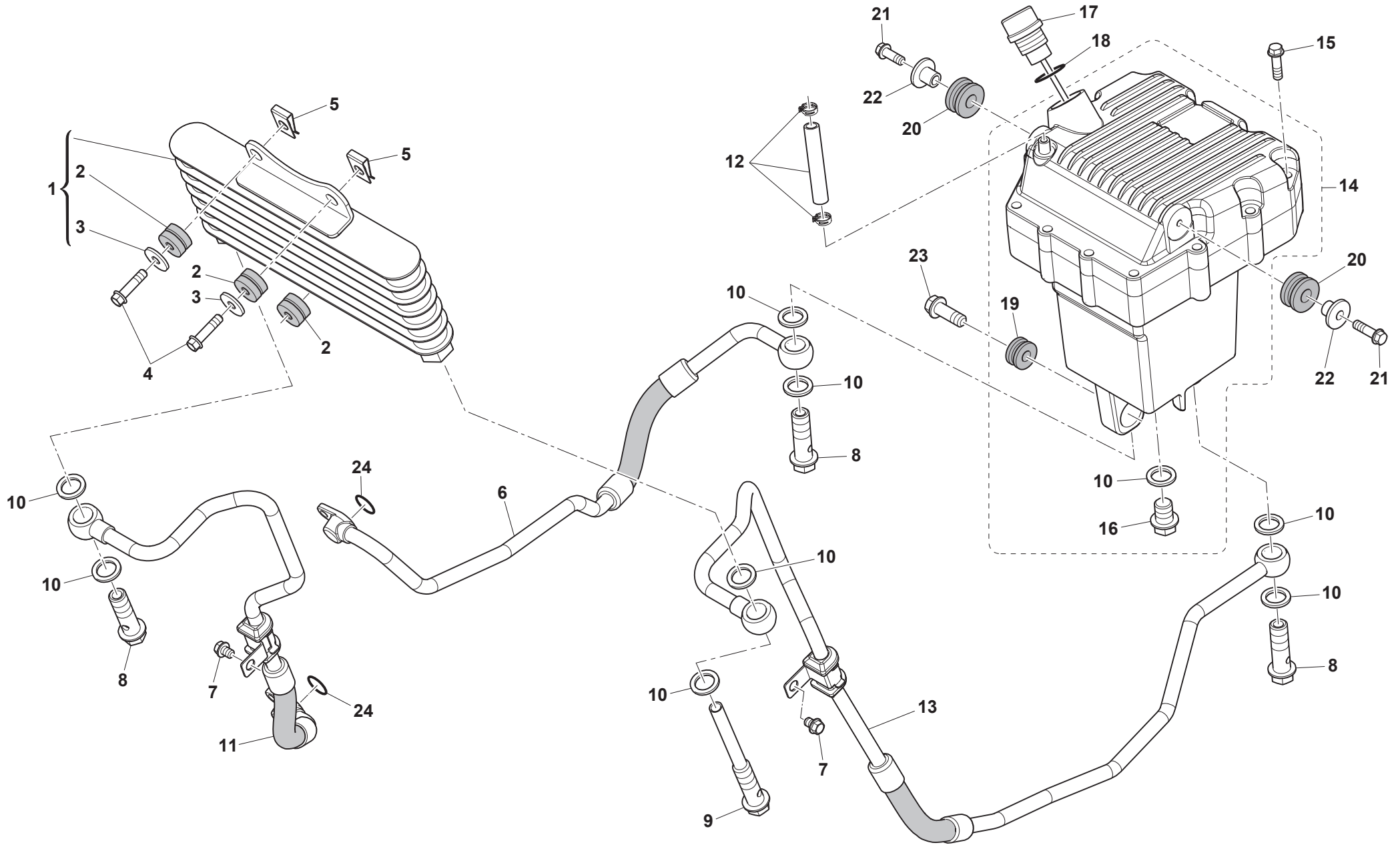



ACE OF SPADES

IMPIANTO DI RAFFREDDAMENTO OLIO - OIL COOLING SYSTEM
INSTALLATION DE REFROIDISSEMENT HUILE - ÖL SCHMIERUNGSSYSTEM
EQUIPO DE ENFRIAMIENTO ACEITE

TAVOLA
DRAWING
TABLE
BILD
TABLA

17

Note Notes Notes Markas Notas	Pos. No. Index Pos.	N. Cod. Code No. Nr. Code Code Nr N. Cod.	Q.tà Q.ty Q.te M.ge C.ad	DENOMINAZIONE	NAME	DESIGNATION	BESHREIBUNG	DENOMINACION
	1	F000A00447	1	RADIATORE OLIO COMPLETO	OIL COOLER ASSY	RADIATEUR HUILE COMPLET	ÖLKÜHLER KOMPLETT	RADIADOR ACEITE COMPLETO
	2	F000P00774	3	GOMMINO RADIATORE OLIO	OIL COOLER RUBBER	JOINT EN CAOUTCHOUC	GUMMISCHEIBE	GOMA
	3	F000P00775	2	DISTANZIALE	SPACER	ENTRETOISE	ABSTANDHALTER	DISTANCIADOR
	4	Z00062729	2	VITE TEF M6x25	FLANGED EXAGON HEAD SCREW M6x25	BOULON DE BRIDE M6x25	FLANSCHENSCHRAUBE M6x25	TORNILLO DE REBORDE M6x25
	5	U00046893	2	DADO A GRAFFETTA M6	CLIP NUT M6	ECROU À AGRAFE M6	SICHERUNGSMUTTER M6	TUERCA DE CLIP M6
	6	F000P00452	1	TUBO SERBATOIO-MOTORE	OIL PIPE TANK-ENGINE	TUBE RÉSERVOIR-MOTEUR	ROHR TANK-MOTOR	TUBO DEPÓSITO-MOTOR
	7	ZH0067545	2	VITE TEF M6x8	FLANGED EXAGON HEAD SCREW M6x8	BOULON DE BRIDE M6x8	FLANSCHENSCHRAUBE M6x8	TORNILLO DE REBORDE M6x8
	8	72012140	3	VITE FORATA M12x1,25x30	LIQUID BOLT M12x1,25x30	VIS M12x1,25x30	SCHRAUBE M12x1,25x30	TORNILLO M12x1,25x30
	9	F000P00742	1	VITE FORATA SPECIALE	SPECIAL LIQUID BOLT	VIS SPÉCIAUX	SPEZIALSCHRAUBE	TORNILLO ESPECIAL
	10	F000P01650	9	ROSETTA DI TENUTA	SEALING WASHER	RONDELLE D'ETANCHEITE	DICHTUNGSSCHEIBE	ARANDELA DE ESTANQUEIDAD
	11	F000A00843	1	TUBO MOTORE-RADIATORE	PIPE ENGINE-TANK	TUBE MOTEUR-RÉSERVOIR	ROHR MOTOR-TANK	TUBO MOTOR-DEPÓSITO
	12	17060151	1	TUBO TESTA-SERBATOIO CON CLIPS	CYLINDER HEAD-OIL TANK HOSE WITH CLIPS	TUBE MOTEUR-RÉSERVOIR	ROHR MOTOR-TANK	TUBO MOTOR-DEPÓSITO
	13	F000A00844	1	TUBO RADIATORE-SERBATOIO	OIL PIPE COOLER-TANK	TUBE RADIATEUR-RÉSERVOIR	ROHR ÖLKÜHLER-TANK	TUBO RADIADOR-DEPÓSITO
	14	M000A00643	1	ASS. SERBATOIO OLIO	OIL TANK ASSY	RÉSERVOIR D'HUILE COMPLET	ÖLBEHÄLTER KOMPLETT	DEPÓSITO ACEITE COMPLETO
	15	72010387	12	VITE TEF M6x28	FLANGED EXAGON HEAD SCREW M6x28	BOULON DE BRIDE M6x28	FLANSCHENSCHRAUBE M6x28	TORNILLO DE REBORDE M6x28
	16	72012089	1	TAPPO OLIO INFERIORE	LOWER OIL CAP	BOUCHON	STOPFEN	TAPON
	17	73010172	1	TAPPO OLIO	OIL CAP	BOUCHON	STOPFEN	TAPON
	18	72150018	1	ANELLO OR	OIL CAP O-RING	JOINT TORIQUE	O-RING	JUNTA TORICA
	19	73012333	1	SILENT-BLOCK	SILENT-BLOCK	SILENT-BLOCK	SILENT-BLOCK	SILENT-BLOCK
	20	73012321	2	GOMMINO	RUBBER RING	JOINT EN CAOUTCHOUC	GUMMISCHEIBE	GOMA
	21	Z00062728	2	VITE TEF M6x20	FLANGED EXAGON HEAD SCREW M6x20	BOULON DE BRIDE M6x20	FLANSCHENSCHRAUBE M6x20	TORNILLO DE REBORDE M6x20
	22	72040551	2	BUSSOLA FLANGIATA Ø6,5x18x7	FLANGED BUSH Ø6,5x18x7	DOUILLE À BRIDE Ø6,5x18x7	FLANSCHBUCHSE Ø6,5x18x7	CASQUILLO CON BRIDA Ø6,5x18x7
	23	8A00B1959	1	VITE TEF M8x30	FLANGED EXAGON HEAD SCREW M8x30	BOULON DE BRIDE M8x30	FLANSCHENSCHRAUBE M8x30	TORNILLO DE REBORDE M8x30
	24	72150213	2	ANELLO OR	O-RING	JOINT TORIQUE	O-RING	JUNTA TORICA

VEDI TAVOLA 1
SEE DRAWING 1
VOIR TABLE 1
SEHEN BILD 1
VER TABLA 1

VEDI TAVOLA 15
SEE DRAWING 15
VOIR TABLE 15
SEHEN BILD 15
VER TABLA 15

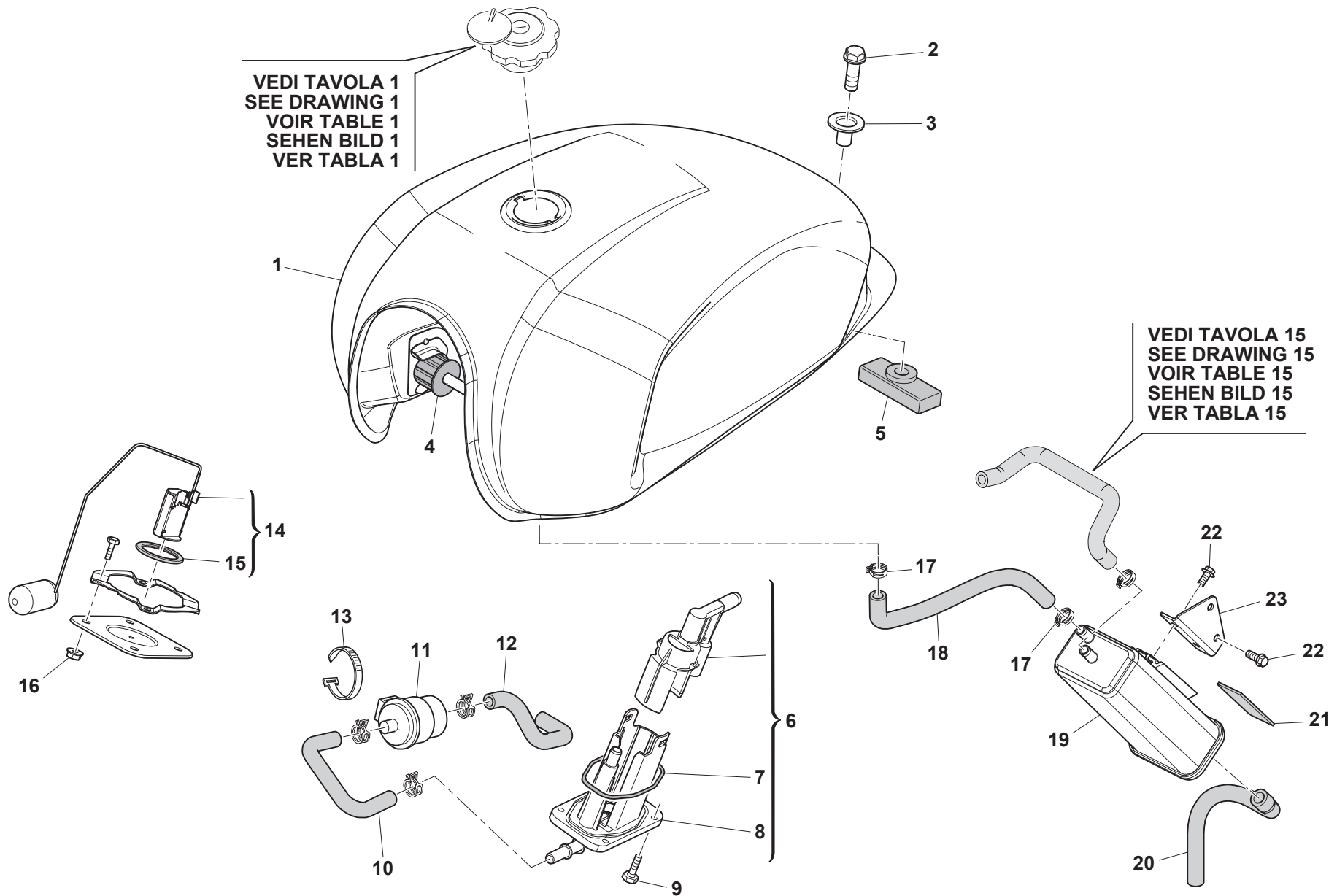



ACE OF SPADES

SERBATOIO CARBURANTE - FUEL TANK
RESERVOIR CARBURANT - KRAFTSTOFFBEHALTER
DEPOSITO GASOLINA

TAVOLA
DRAWING
TABLE
BILD
TABLA

18

Note Notes Marke Notas	Pos. No. Index Pos.	N. Cod. Code No. Nr. Code Code Nr N. Cod.	Q.tà Q.ty Q.te M.ge C.ad	DENOMINAZIONE	NAME	DESIGNATION	BESHREIBUNG	DENOMINACION
	1	F0B0P02292	1	ASS. SERBATOIO CARBURANTE	FUEL TANK ASSY	RESERVOIR DE CARBURANT COMPLET	KRAFTSTOFFTANK KOMPLETT	DEPOSITO COMBUSTIBLE COMPLETO
	2	72011245	1	VITE TEF M8x30	FLANGED EXAGON HEAD SCREW M8x30	BOULON DE BRIDE M8x30	FLANSCHENSCHRAUBE M8x30	TORNILLO DE REBORDE M8x30
	3	70120233	1	BUSSOLA	BUSHING	DOUILLE	BUCHSE	CASQUILLO
	4	F000P02483	2	TAMPONE LATERALE SERBATOIO	FRONT DAMPING MAT	TAMPON LATÉRALE	PUFFER SEITLICH	TACO LATERAL
	5	F000P02482	1	TAMPONE POSTERIORE SERBATOIO	REAR DAMPING MAT	TAMPON ARRIÈRE	PUFFER HINTEN	TACO TRASERO
	6	31350039	1	POMPA BENZINA	FUEL PUMP	POMPE À CARBURANT	BENZINPUMPE	BOMBA GASOLINA
	7	31350081	1	GUARNIZIONE POMPA BENZINA	FUEL PUMP GASKET	JOINT POMPE DE CARBURANT	DICHTUNG PUMPE	JUNTA BOMBA COMBUSTIBLE
	8	31350083	1	PIASTRA METALLICA	METALLIC PLATE	PLAQUE	PLATTE	PLACA
	9	72030657	4	VITE M4x16	BOLT M4x16	VIS M4x16	SCHRAUBE M4x16	TORNILLO M4x16
	10	F000A00761	1	TUBO MANDATA BENZINA CON CLIPS	PUMP- FUEL FILTER HOSE WITH CLIPS	TUYAU DE REFOULEMENT	VORLAUFROHR	TUBO ALIMENTACIÓN
	11	F000P00915	1	FILTRO BENZINA	FUEL FILTER	FILTRE DE CARBURANT	BENZINFILTER	FILTRO COMBUSTIBLE
	12	F000P00913	1	TUBO FILTRO-INIETTORE CON CLIPS	FUEL FILTER-INJECTOR HOSE WITH CLIPS	TUBE FILTRE-INJECTEUR	ROHR FILTER-EINSPRITZDÜSE	TUBO FILTRO-INYECTOR
	13	8D0091687	1	FASCETTA	CLAMP	COLLIER	SCHELLE	ABRAZADERA
	14	31130115	1	SENSORE LIVELLO BENZINA	FUEL SENDER ASSY	CAPTEUR	SENSOR	SENSOR
	15	31130117	1	GUARNIZIONE	GASKET	JOINT	DICHTUNG	JUNTA
	16	72020178	4	DADO M6	NUT M6	ECROU M6	MUTTER M6	TUERCA M6
	17	8B0091687	1	FASCETTA STRINGITUBO D10	METALLIC CLIP D10	COLLIERT D10	SCHELLE D10	ABRAZADERA D10
	18	F000P01488	1	TUBO INGRESSO CANISTER CON CLIPS	CANISTER INTAKE HOSE WITH CLIPS	TUYAU DE REFOULEMENT CANISTER	VORLAUFROHR KANISTER	TUBO ALIMENTACIÓN CANISTER
	19	18210017	1	CANISTER	CANISTER	CANISTER	KANISTER	CÁNISTER
	20	F000P01489	1	TUBO USCITA CANISTER CON CLIPS	CANISTER OUTLET HOSE WITH CLIPS	TUYAU DE SORTIE CANISTER	ANSCHLUSSROHR KANISTER	TUBO SALIDA CANISTER
	21	800037140	1	ANTIVIBRANTE ADESIVO	SILENT-BLOCK ADHESIVE	ADHÉSIF ANTIVIBRATION	AUFKLEBER SCHWINGUNGSDAMFER	ANTIVIBRADOR ADHESIVO
	22	ZH0067545	4	VITE TEF M6x12	FLANGED EXAGON HEAD SCREW M6x12	BOULON DE BRIDE M6x12	FLANSCHENSCHRAUBE M6x12	TORNILLO DE REBORDE M6x12
	23	F000P01490	1	SUPPORTO CANISTER	CANISTER SUPPORT	SUPPORT CANISTER	HALTERUNG KANISTER	SOPORTE CANISTER

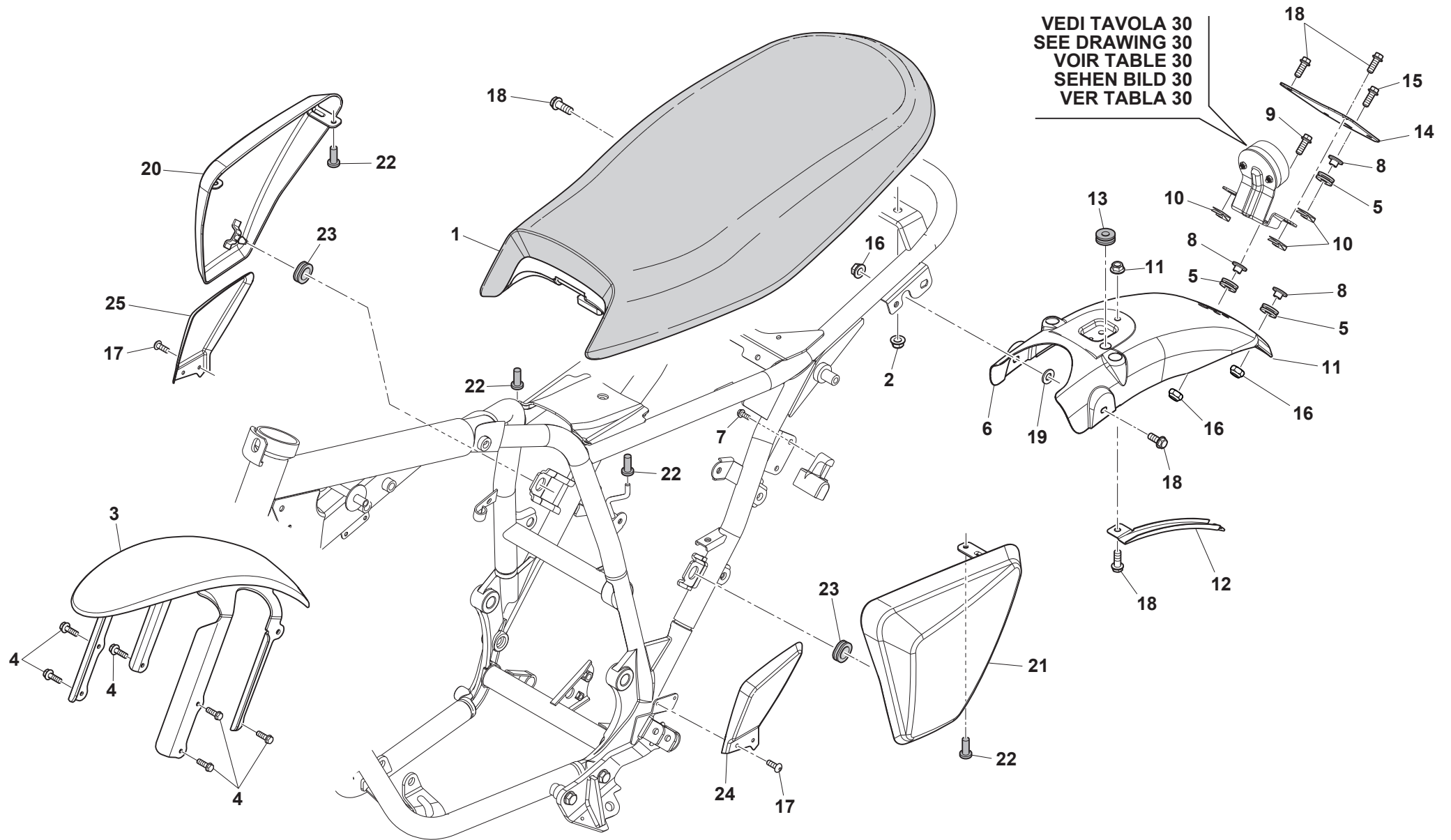

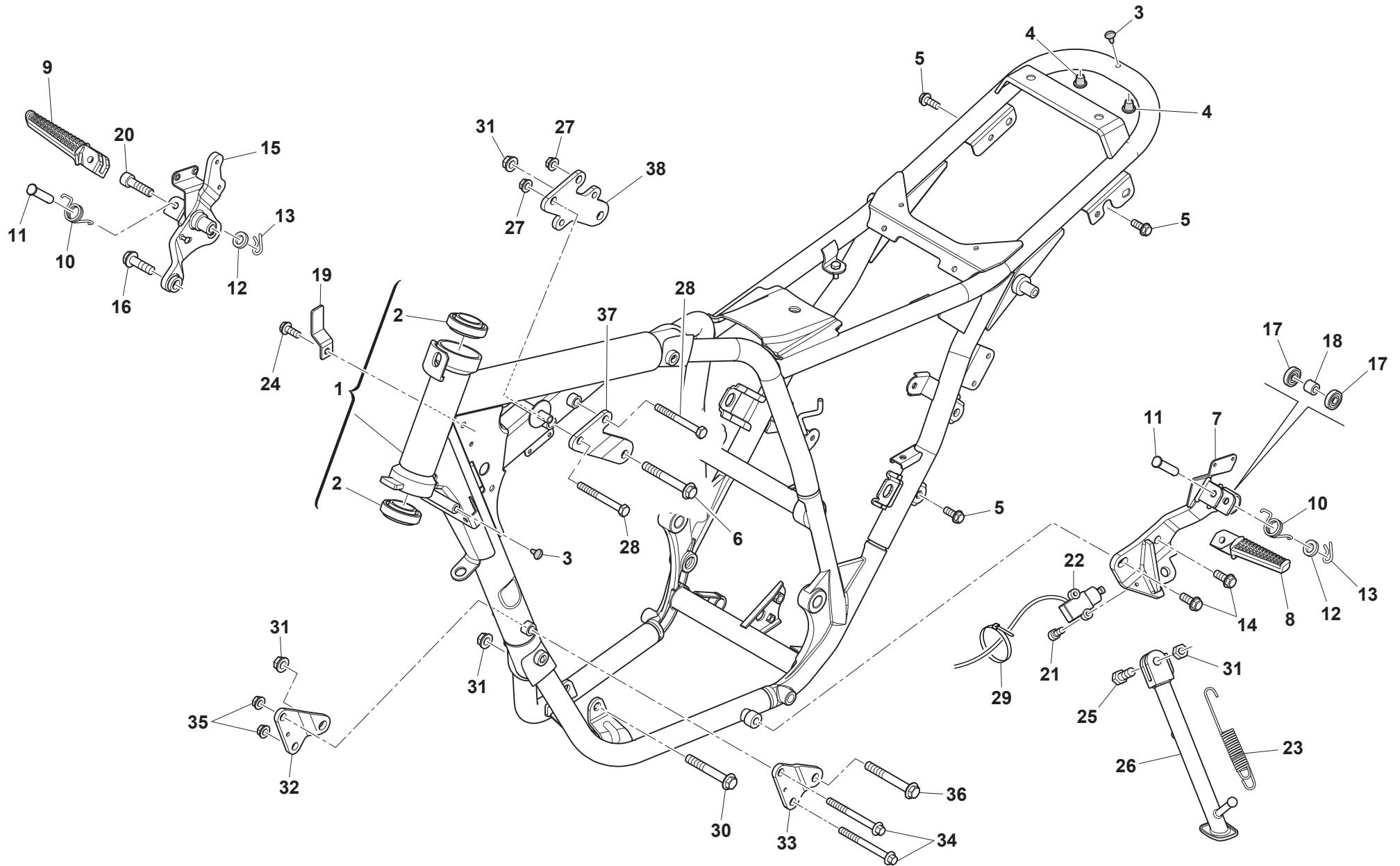



ACE OF SPADES

TELAIO, PEDANE - FRAME, FOOT RESTS CADRE, REPOSE PIEDS - RAHMEN, FUSSBRETT BASTIDOR, REPOSAPIES

TAVOLA
DRAWING
TABLE
BILD
TABLA

20

Note Notes Notes Marke Notas	Pos. No. N. Index Pos.	N. Cod. Code No. Nr. Code Code Nr N. Cod.	Q.tà Q.ty Q.te M.ge C.ad	DENOMINAZIONE	NAME	DESIGNATION	BESHREIBUNG	DENOMINACION
	1	F0A0A01474	1	TELAIO CON CUSCINETTI	FRAME WITH BEARINGS	CHÂSSIS AVEC ROULEMENTS	RAHMEN MIT LAGERN	CHASIS CON COJINETES
	2	800087243	2	CUSCINETTO A RULLI CONICI	TAPERED ROLLER BEARING	ROULEMENT À ROULEAUX CONIQUES	KEGELROLLENLAGER	COJINETE DE RODILLOS CÓNICOS
	3	800058394	3	TAMPONE IN GOMMA	RUBBER BUFFER	TAMPON	PUFFER	TACO
	4	F000P01119	2	TAMPONE IN GOMMA	RUBBER BUFFER	TAMPON	PUFFER	TACO
	5	Z00069056	4	VITE TEF M8x20	FLANGED EXAGON HEAD SCREW M8x20	BOULON DE BRIDE M8x20	FLANSCHENSCHRAUBE M8x20	TORNILLO DE REBORDE M8x20
	6	ZT0069138	1	VITE TEF M10x70	SCREW M10x70	BOULON DE BRIDE M10x70	FLANSCHENSCHRAUBE M10x70	TORNILLO DE REBORDE M10x70
	7	F000A00445	1	SUPPORTO PEDANA SINISTRA	L.H. FOOTREST SUPPORT	SUPPORT REPOSE-PIEDS GAUCHE	HALTERUNG FUßRASTE LINKS	SOPORTE ESTRIBO IZQUIERDA
	8	F000P00698	1	PEDANA SINISTRA	L.H. FOOTREST	REPOSE-PIEDS GAUCHE	FUßRASTE LINKS	ESTRIBO IZQUIERDA
	9	F000P00699	1	PEDANA DESTRA	R.H. FOOTREST	REPOSE-PIEDS DROITE	FUßRASTE RECHTS	ESTRIBO DERECHA
	10	F000P00822	2	MOLLA PEDANA SINISTRA	SPRING	RESSORT	FEDER	MUELLE
	11	F000P00823	2	PERNO	PIN	AXE	BOLZEN	EJE
	12	Z00056377	2	ROSETTA	WASHER	RONDELLE	UNTERLEGSCHIEBE	ARANDELA
	13	64ND20068	2	COPIGLIA	SPLIT PIN	GOUPILLE	SPLINT	PASADOR
	14	ZG0062797	2	VITE TEF M10x22	FLANGED EXAGON HEAD SCREW M10x22	BOULON DE BRIDE M10x22	FLANSCHENSCHRAUBE M10x22	TORNILLO DE REBORDE M10x22
	15	F000A00446	1	SUPPORTO PEDANA DESTRA	R.H. FOOTREST SUPPORT	SUPPORT REPOSE-PIEDS DROITE	HALTERUNG FUßRASTE RECHTS	SOPORTE ESTRIBO DERECHA
	16	ZF0062797	1	VITE TEF M10x30	FLANGED EXAGON HEAD SCREW M10x30	BOULON DE BRIDE M10x30	FLANSCHENSCHRAUBE M10x30	TORNILLO DE REBORDE M10x30
	17	70090215	2	CUSCINETTO 6900	BEARING 6900	ROULEMENT 6900	LAGER 6900	COJINETE 6900
	18	70180041	1	DISTANZIALE INTERNO	INTERNAL SPACER	ENTRETOISE INTÉRIEUR	INTERNER ABSTANDHALTER	DISTANCIADOR INTERNO
	19	F000P02232	1	PIASTRINO GUIDA CAVO	CABLE GUIDE PLATE	PLAQUE GUIDE-CÂBLE	KABELFÜHRUNG	PLACA GUÍA CABLE
	20	YN0082751	1	VITE TCEIF M10x40	SCREW TCEIF M10x40	VIS TCEIF M10x40	SCHRAUBE TCEIF M10x40	TORNILLO TCEIF M10x40
	21	60ND07330	2	VITE TCEI M5x16	SCREW TCEI M5x16	VIS TCEI M5x16	SCHRAUBE TCEI M5x16	TORNILLO TCEI M5x16
	22	31120016	1	INTERRUPTORE CAVALLETTO	POWEROFF SWITCH	INTERRUPTEUR	SCHALTER	INTERRUPTOR
	23	F000P02470	1	MOLLA	SPRING	RESSORT	FEDER	MUELLE
	24	ZH0067545	1	VITE M6x12	SCREW M6x12	VIS M6x12	SCHRAUBE M6x12	TORNILLO M6x12
	25	72030710	1	VITE ROTAZIONE CAVALLETTO LATERALE	SIDE STAND SCREW	VIS BÉQUILLE	SCHRAUBE STÄNDER	TORNILLO CABALLETE
	26	FOA0P01484	1	CAVALLETTO LATERALE	LATERAL STAND	BÉQUILLE	STÄNDER	CABALLETE LATERAL
	27	Y00043928	2	DADO FLANGIATO M8	FLANGED NUT M8	ECROU BRIDE M8	FLANSCHMUTTER M8	TUERCA CON BRIDA M8
	28	F000P02576	2	VITE TEF M8x70	FLANGED EXAGON HEAD SCREW M8x70	BOULON DE BRIDE M8x70	FLANSCHENSCHRAUBE M8x70	TORNILLO DE REBORDE M8x70
	29	800056444	3	FASCETTA L=188 mm	CLAMP L=188 mm	COLLIER L=188 mm	SHELLE L=188 mm	ABRAZADERA L=188 mm
	30	ZT0069138	1	VITE TEF M10x70	SCREW M10x70	BOULON DE BRIDE M10x70	FLANSCHENSCHRAUBE M10x70	TORNILLO DE REBORDE M10x70
	31	Z00042022	1	DADO FLANGIATO M10	FLANGED NUT M10	ECROU BRIDE M10	FLANSCHMUTTER M10	TUERCA CON BRIDA M10
	32	FOA0P00482	1	PIASTRA ANT. DESTRA MOTORE	R.H. FRONT ENGINE PLATE	PLAQUE MOTEUR AV. DROIT	PLATTE MOTOR VORNE RECHTS	PLACA MOTOR DEL. DER.
	33	FOA0P00483	1	PIASTRA ANT. SINISTRA MOTORE	L.H. FRONT ENGINE PLATE	PLAQUE MOTEUR AV. GAUCHE	PLATTE MOTOR VORNE LINKE	PLACA MOTOR DEL. IZQ.

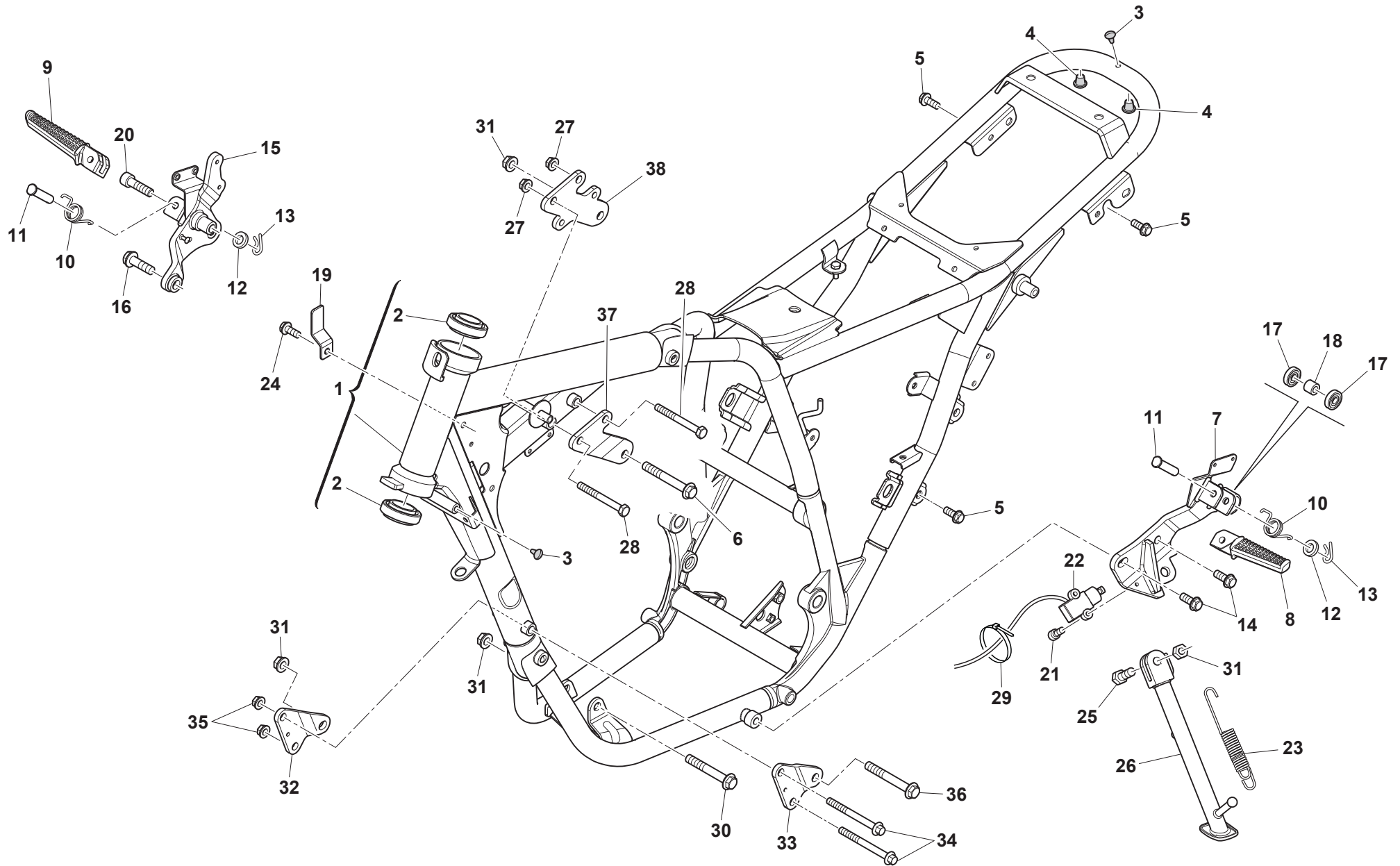

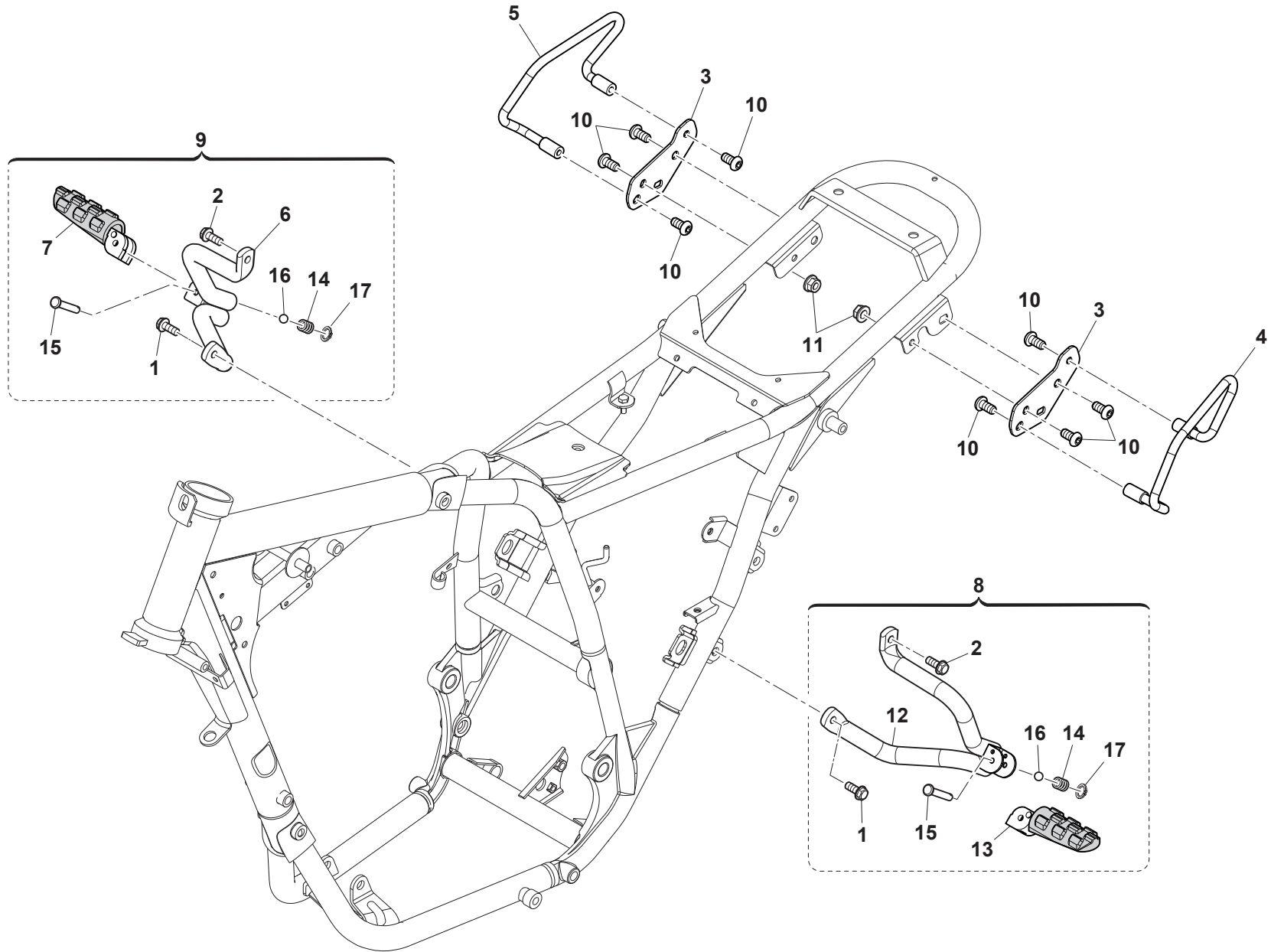

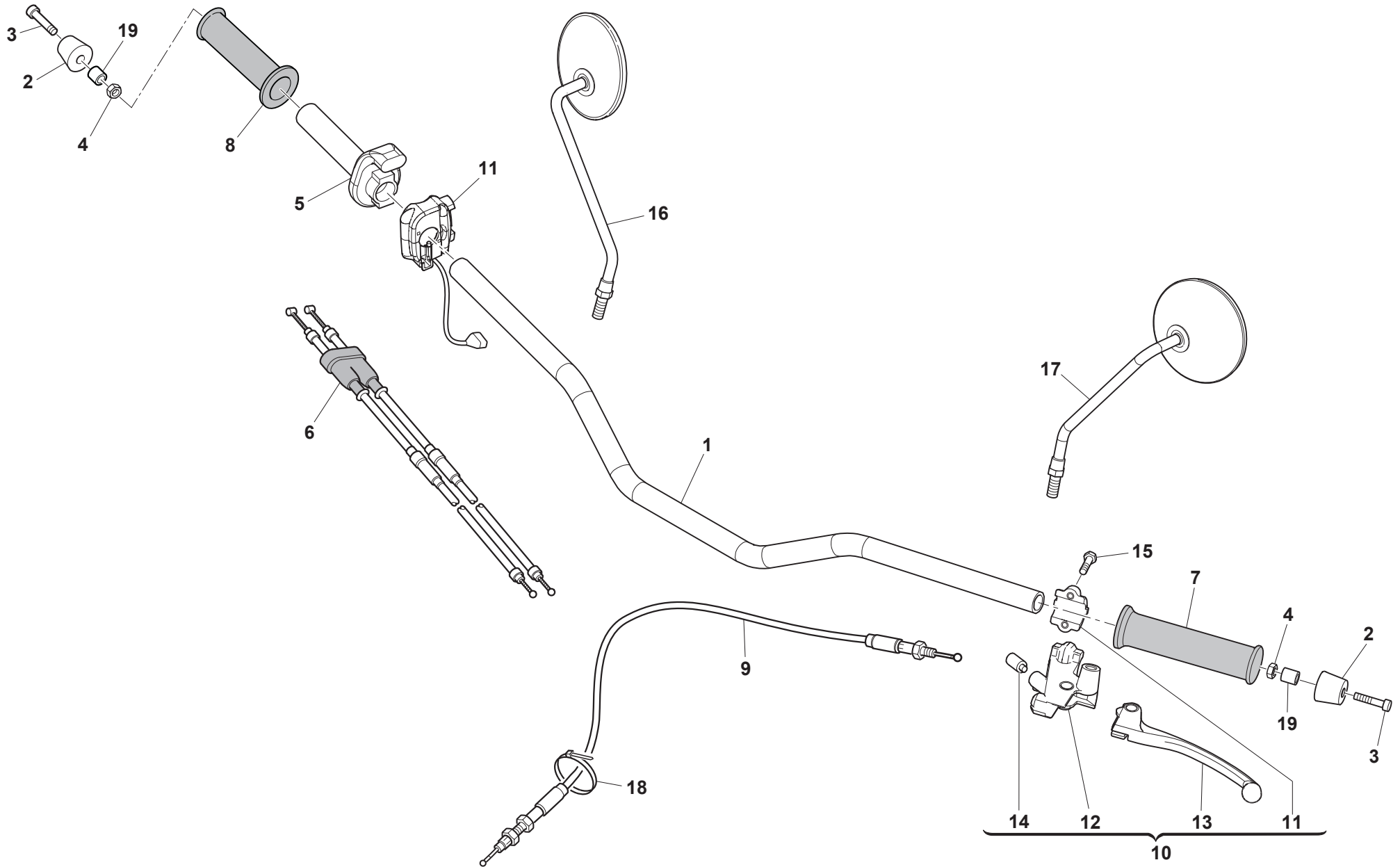



SOSPENSIONE ANTERIORE - FRONT FORK ASSEMBLY SUSPENSION AVANT - VORDERTELESKOPGABEL SUSPENSION DELANTERA

Note Notes Notas	Pos. No. Index Pos.	N. Cod. Code No. Nr. Code Code Nr N. Cod.	Q.tà Q.ty Q.te M.ge C.ad	DENOMINAZIONE	NAME	DESIGNATION	BESHREIBUNG	DENOMINACION
	1	FB00A00655	1	ASS. SOSPENSIONE ANTERIORE	FRONT SUSPENSION ASSY	SUSPENSION AVANT	RADAUFHAENGUNG VORDER	SUSPENSION DELANTERA
	2	8A0087717	1	GHIERA PER PERNO DI STERZO	RING NUT	BAGUE	GEWINDERING	TUERCA ANULAR
	3	F000P03137	1	TESTA DI STERZO	STEERING HEAD	TETE DE DIRECTION	LENKKOPF	CABEZAL DE DIRECCIÓN
	4	8A00B0850	1	BASE DI STERZO CON PERNO	BOTTOM YOKE WITH PIN	BASE DE DIRECTION AVEC AXE	LENKLAGER MIT BOLZEN	BASE DE DIRECCIÓN CON EJE
	5	FA00A00432	1	ASSIEME GAMBE FORCELLA	FORK LEGS ASSY	ENSEMBLE FOURCHE	GABELGRUPPE	GRUPO HORQUILLA
	6	F000A00656	1	GAMBA DESTRA COMPLETA	COMPLETE R.H. SHOCK ABSORBER	BRANCHE DROITE COMPLÈTE	FEDERBEIN RECHTS KOMPLETT	PATA DER. COMPLETA
	7	F000A00657	1	GAMBA SINISTRA COMPLETA	COMPLETE L.H. SHOCK ABSORBER	BRANCHE GAUCHE COMPLÈTE	FEDERBEIN LINKE KOMPLETT	PATA IZQ. COMPLETA
	8	Z00062796	8	VITE TEF M8x40	FLANGED EXAGON HEAD SCREW M8x40	BOULON DE BRIDE M8x40	FLANSCHENSCHRAUBE M8x40	TORNILLO DE REBORDE M8x40
	9	8A0069315	1	DADO M26	NUT M26	ECROU M26	MUTTER M26	TUERCA M26
	10	800087736	1	ROSETTA	WASHER	RONDELLE	UNTERLEGSSCHEIBE	ARANDELA
	11	800087745	2	GUARNIZIONE	GASKET	JOINT	DICHTUNG	JUNTA
	12	F000P00912	1	TAPPO	PLUG	BOUCHON	STOPFEN	TAPON
	13	80A0H2355	2	MORSETTO INFERIORE MANUBRIO	LOWER CLAMP	ETRIER INFÉRIEUR	KLEMME UNTEN	BORNE INFERIOR
	14	8A00A6683	2	DISTANZIALE	SPACER	ENTRETOISE	ABSTANDHALTER	DISTANCIADOR
	15	800060233	4	SILENTBLOCK	SILENTBLOCK	SILENTBLOCK	SILENTBLOCK	SILENTBLOCK
	16	800060234	4	ROSETTA	WASHER	RONDELLE	UNTERLEGSSCHEIBE	ARANDELA
	17	60ND01222	2	VITE TE M10x80	FLANGED EXAGON HEAD SCREW M10x80	BOULON DE BRIDE M10x80	FLANSCHENSCHRAUBE M10x80	TORNILLO DE REBORDE M10x80
	18	Z00061314	2	DADO AUTOBLOCCANTE M10x1,5	SELF-LOCKING NUT M10x1,5	ECROU AUTOBLOQUANT M10x1,5	SELBSTSICHERNDE MUTTER M10x1,5	TUERCA AUTOBLOCCANTE M10x1,5
	19	80A0B0522	1	MORSETTO SUPERIORE MANUBRIO	UPPER CLAMP	ETRIER SUPÉRIEUR	KLEMME OBEN	BORNE SUPERIOR
	20	ZC0069056	4	VITE TEF M8x1,25x30 CH12	FLANGED EXAGON HEAD SCREW M8x1,25x30	BOULON DE BRIDE M8x1,25x30 CH12	FLANSCHENSCHRAUBE M8x1,25x30 CH12	TORNILLO DE REBORDEM8x1,25x30CH12
	21	8000H3016	2	DISTANZIALE	SPACER	ENTRETOISE	ABSTANDHALTER	DISTANCIADOR

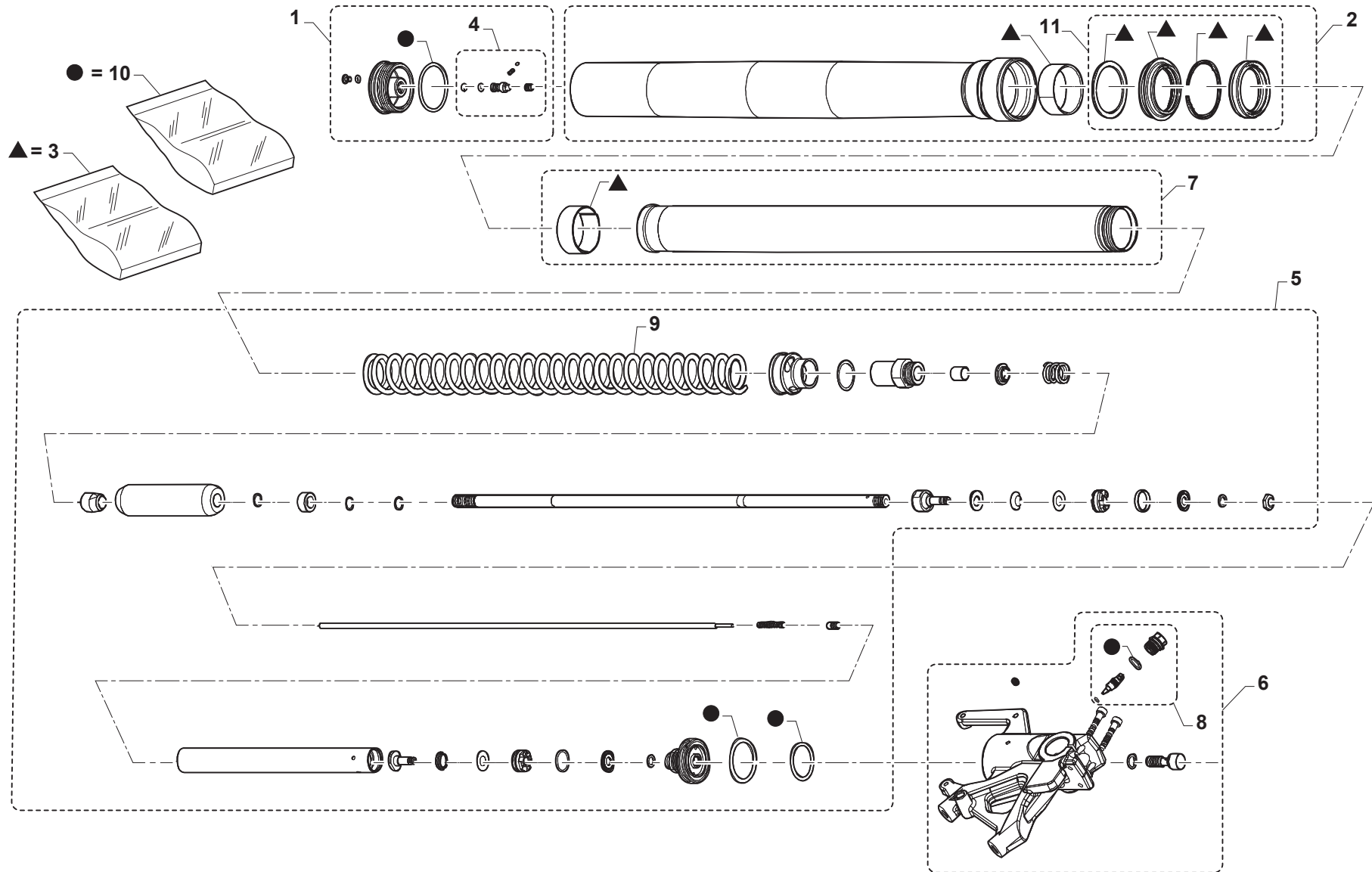

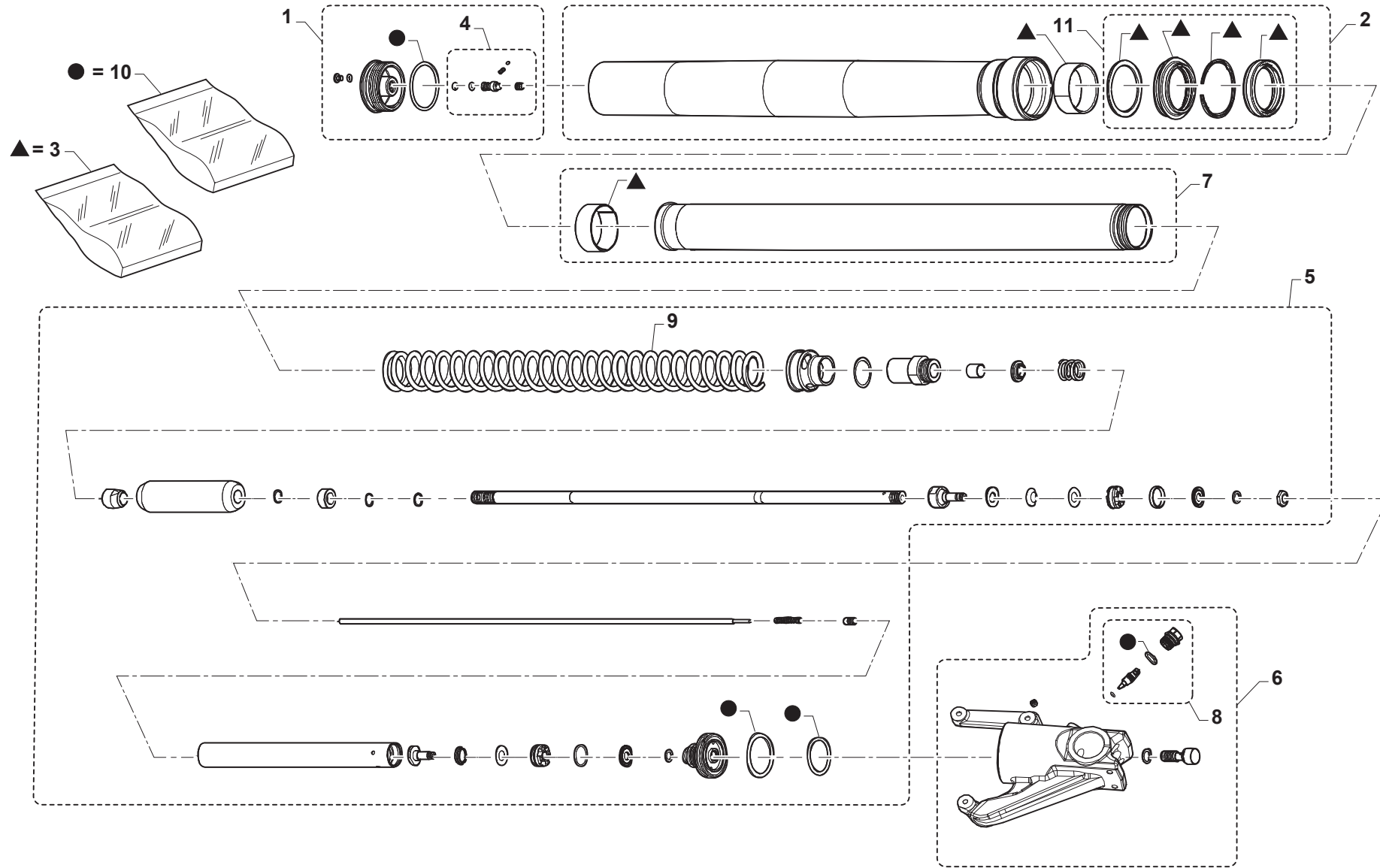

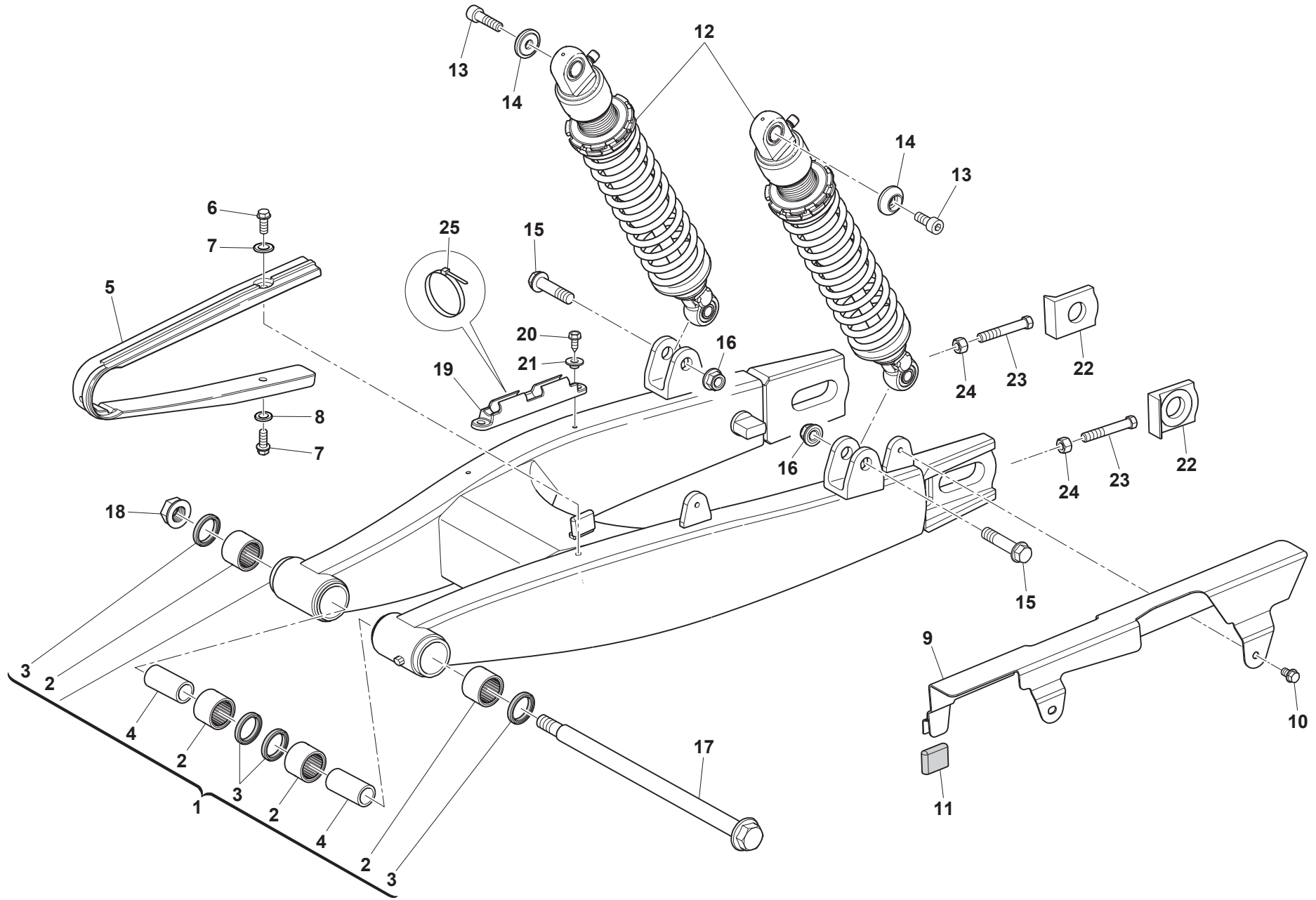



ACE OF SPADES

FORCELLONE E AMMORTIZZATORE POSTERIORE - REAR SWING ARM AND SUSPENSION FOURCHE AT SUSPENSION ARRIERE - HINTERHAUFHANGUNG HORQUILLA Y SUSPENSION TRASERA

TAVOLA
DRAWING
TABLE
BILD
TABLA

23

Note Notes Marke Notas	Pos. No. N. Index Pos.	N. Cod. Code No. Nr. Code Code Nr N. Cod.	Q.tà Q.ty Q.te M.ge C.ad	DENOMINAZIONE	NAME	DESIGNATION	BESHREIBUNG	DENOMINACION
	1	F000A00440	1	FORCELLONE COMPLETO	COMPLETE SWINGING ARM	BRAS OSCILLANT COMPLET	SCHWINGE KOMPLETT	BASCULANTE COMPLETO
	2	41280358	4	CUSCINETTO 6902	BEARING 6902	ROULEMENT 6902	LAGER 6902	COJINETE 6902
	3	72110226	4	GUARNIZIONE FB 20x30x7	GASKET FB 20x30x7	JOINT FB 20x30x7	DICHTUNG FB 20x30x7	JUNTA FB 20x30x7
	4	70280008	2	BUSSOLA DISTANZIALE Ø20-Ø15-L=69,1	BUSHING Ø20-Ø15-L=69,1	DOUILLE Ø20-Ø15-L=69,1	BUCHSE Ø20-Ø15-L=69,1	CASQUILLO Ø20-Ø15-L=69,1
	5	73110086	1	PATTINO CATENA	CHAIN SLIDER	PATIN CHAÎNE	KETTENSANNERAUFLAGE	PATÍN CADENA
	6	72030085	2	VITE M5x12	SCREW M5x12	VIS M5x12	SCHRAUBE M5x12	TORNILLO M5x12
	7	72040554	1	RONDELLA OVALE	OVAL WASHER	RONDELLE	UNTERLEGSCHIEBE	ARANDELA
	8	72040059	1	RONDELLA	WASHER	RONDELLE	UNTERLEGSCHIEBE	ARANDELA
	9	F000P03138	1	COPRICATENA	CHAIN GUARD	CARTER DE CHAÎNE	KETTENKASTEN	CUBRECADENA
	10	Z00062725	2	VITE TEF M6x10	FLANGED EXAGON HEAD SCREW M6x10	BOULON DE BRIDE M6x10	FLANSCHENSCHRAUBE M6x10	TORNILLO DE REBORDE M6x10
	11	73012153	1	GOMMINO	RUBBER RING	JOINT EN CAOUTCHOUC	GUMMISCHIEBE	GOMA
	12	F000P01483	2	AMMORTIZZATORE POSTERIORE	REAR SHOCK ABSORBER	AMORTISSEUR ARRIÈRE COMPLET	STOßDÄMPFER KOMPLETT	AMORTIGUADOR COMPLETO
	13	60ND02555	2	VITE TCEI M8x20	SCREW TCEI M8x20	VIS TCEI M8x20	SCHRAUBE TCEI M8x20	TORNILLO TCEI M8x20
	14	F000P00760	2	RONDELLA CONICA	CONIC SPACER	RONDELLE CONIQUE	UNTERLEGSCHIEBE	ARANDELA CONICA
	15	ZD0062797	2	VITE TEF M10x47	FLANGED EXAGON HEAD SCREW M10x47	BOULON DE BRIDE M10x47	FLANSCHENSCHRAUBE M10x47	TORNILLO DE REBORDE M10x47
	16	Z00042022	2	DADO AUTOBLOCCANTE M10	SELF-LOCKING NUT M10	ECROU AUTOBLOQUANT M10	SELBSTSICHERNDE MUTTER M10	TUERCA AUTOBLOCANTE M10
	17	70030169	1	PERNO FORCELLONE	SWINGING ARM PIN	AXE BRAS OSCILLANT	BOLZEN SCHWINGE	EJE BASCULANTE
	18	72020488	1	DADO M14x1,5	NUT M14x1,5	ECROU M14x1,5	MUTTER M14x1,5	TUERCA M14x1,5
	19	8000B1166	1	PASSATUBO	HOSE RING	PASSE-TUBE	LEITUNGSDURCHFÜHRUNG	PASATUBO
	20	Z00067997	2	VITE TEF M5x12	FLANGED EXAGON HEAD SCREW M5x12	BOULON DE BRIDE M5x12	FLANSCHENSCHRAUBE M5x12	TORNILLO DE REBORDE M5x12
	21	800069282	2	BUSSOLA D14-D7-D5,25	BUSHING D14-D7-D5,25	DOUILLE D14-D7-D5,25	BUCHSE D14-D7-D5,25	CASQUILLO D14-D7-D5,25
	22	54140106	2	TENDICATENA	CHAIN TENSIONER	TENDEUR DE CHAÎNE	KETTENSANNER	SENSOR DE CADENA
	23	72010119	2	VITE TE M8x50	HEXAGON SOCKET-HEAD BOLT M8x50	VIS M8x50	SCHRAUBE M8x50	TORNILLO M8x50
	24	72020016	2	DADO M8	NUT M8	ECROU M8	MUTTER M8	TUERCA M8
	25	800056783	2	FASCETTA	CLAMP	COLLIER	SHELLE	ABRAZADERA

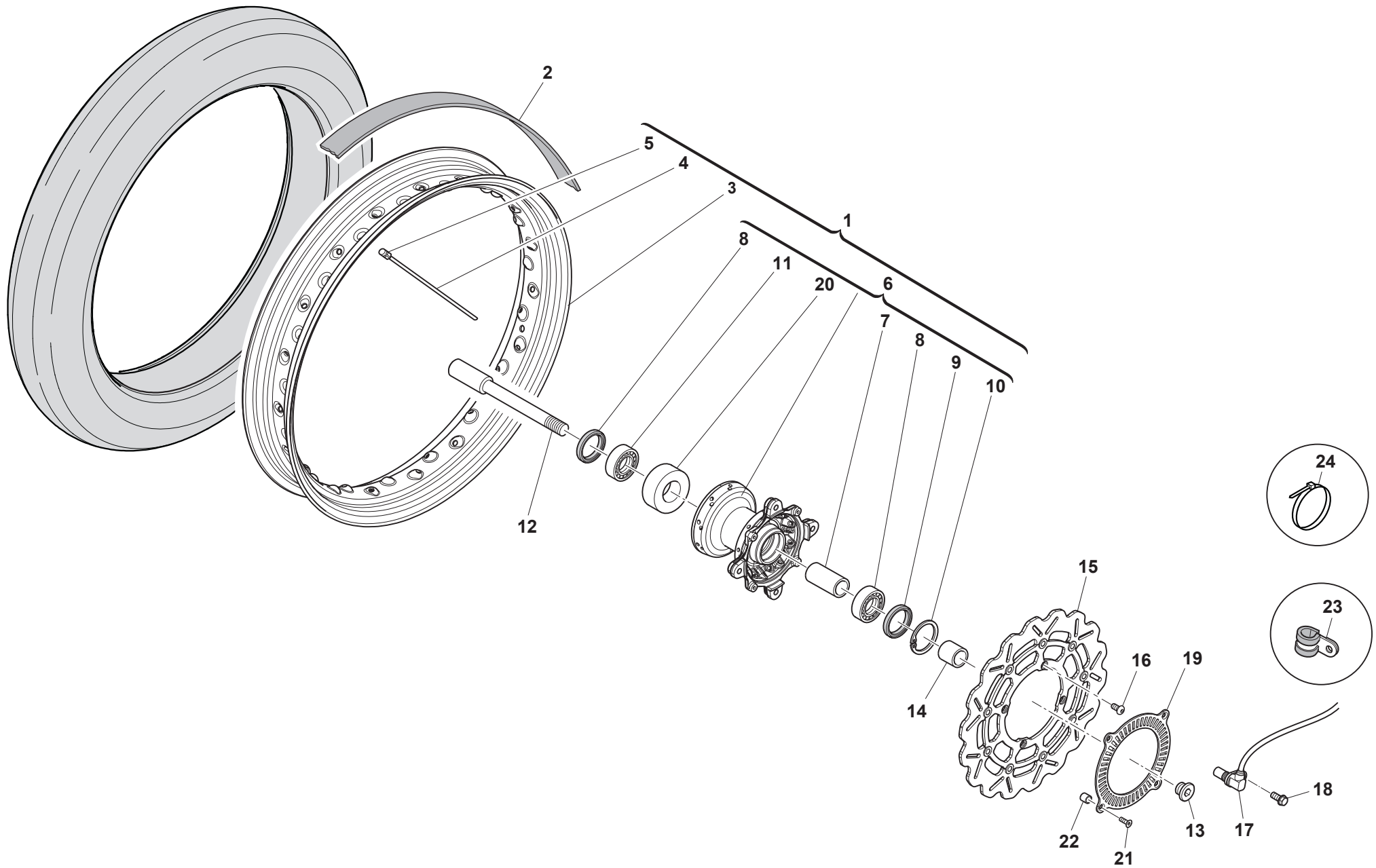



ACE OF SPADES

RUOTA ANTERIORE - FRONT WHEEL ROUE AVANT - VORTERRAD RUEDA DELANTERA

TAVOLA
DRAWING
TABLE
BILD
TABLA

24

Note Notes Marke Notas	Pos. No. N. Index Pos.	N. Cod. Code No. Nr. Code Code Nr N. Cod.	Q.tà Q.ty Q.te M.ge C.ad.	DENOMINAZIONE	NAME	DESIGNATION	BESHREIBUNG	DENOMINACION
	1	F000A01829	1	RUOTA ANTERIORE SENZA PNEUMATICO	FRONT WHEEL WITHOUT TYRE	ROUE AVANT SANS PNEU	VORDERRAD OHNE TYRE	RUEDA DELANTERA SIN NEUMÁTICO
	2	8B0082879	1	PROTEZIONE CAMERA D'ARIA	AIR TUBE PROTECTION	VAINES DE PROTECTION	HULLE	VAINA DE PROTECCION
	3	FOA0P00261	1	CERCHIO RUOTA ANT. 3,50"x17"	FRONT WHEEL RIM 3,50"x17"	JANTE ROUE AVANT 3,50"x17"	FELGE VORDERRAD 3,50"x17"	LLANTA RUEDA DEL. 3,50"x17"
	4	8000H1724	36	RAGGIO	SPOKE	BRAS	SPEICHE	RADIO
	5	69N429004	36	NIPPLO	NIPPLE	NIPPLE	NIPPEL	NIPLE
	6	F000A01823	1	MOZZO RUOTA ANTERIORE	FRONT WHEEL HUB	MOYEU	NABE	CUBO
	7	F000P00120	1	DISTANZIALE INTERNO	INTERNAL SPACER	ENTRETOISE INTÉRIEUR	INTERNER ABSTANDHALTER	DISTANCIADOR INTERNO
	8	800084938	2	CUSCINETTO A SFERE	BALL BEARING	ROULEMENT À BILLES	KUGELLAGER	COJINETE DE BOLAS
	9	8000H6187	1	ANELLO Ø42x28xSP7	SEAL RING Ø42x28xSP7	BAGUE Ø42x28xSP7	RING Ø42x28xSP7	ANILLO Ø42x28xSP7
	10	66N021270	1	ANELLO DI FERMO	SEGER	BAGUE D'ARRET	SICHERUNGSRING	ANILLO DE RETENCION
	11	800022966	1	ANELLO DI TENUTA Ø42x32xSP7	SEALING RING Ø42x32xSP7	BAGUE D'ETANCHEITE Ø42x32xSP7	DICHTUNGSRING Ø42x32xSP7	ANILLO DE ESTANQUEIDAD Ø42x32xSP7
	12	F000P00670	1	PERNO RUOTA	WHEEL AXLE	PIVOT DE ROUE	RADASCHE	EJE RUEDA
	13	800096933	1	TAPPO	PLUG	BOUCHON	STOPFEN	TAPON
	14	F000P00671	1	DISTANZIALE	SPACER	ENTRETOISE	ABSTANDHALTER	DISTANCIADOR
	15	F000P01803	1	DISCO FRENO ANTERIORE	FRONT BRAKE DISC	DISQUE DE FREIN	BREMSSCHEIBE	DISCO FRENO
	16	YA0092876	4	VITE M8x16	BOLT M8x16	VIS M8x16	SCHRAUBE M8x16	TORNILLO M8x16
	17	EA00P01022	1	SENSORE VELOCITÀ	SPEED SENSOR	CAPTEUR DE VITESSE	GESCHWINDIGKEITSSENSOR	SENSOR VELOCIDAD
	18	Z00062726	1	VITE TEF M6x14	FLANGED EXAGON HEAD SCREW M6x14	BOULON DE BRIDE M6x14	FLANSCHENSCHRAUBE M6x14	TORNILLO DE REBORDE M6x14
	19	F000P01032	1	RUOTA FONICA	TONE WHEEL	ROUE PHONIQUE	IMPULSRAD	RUEDA FÓNICA
	20	F000P00121	1	PORTA DISTANZIALE	SPACER HOLDER	SUPPORT ENTRETOISE	HALTERUNG ABSTANDHALTER	SOPORTE DISTANCIADOR
	21	8000H5785	4	VITE	BOLT	VIS	SCHRAUBE	TORNILLO
	22	F000P01792	4	DISTANZIALE	SPACER	ENTRETOISE	ABSTANDHALTER	DISTANCIADOR
	23	F000P02376	1	COLLARE GOMMATO	RUBBER CLAMP	COLLIER EN CAOUTCHOUC	GUMMISCHELLE	ABRAZADERA DE GOMA
	24	800092668	3	FASCETTA	CLAMP	COLLIER	SHELLE	ABRAZADERA

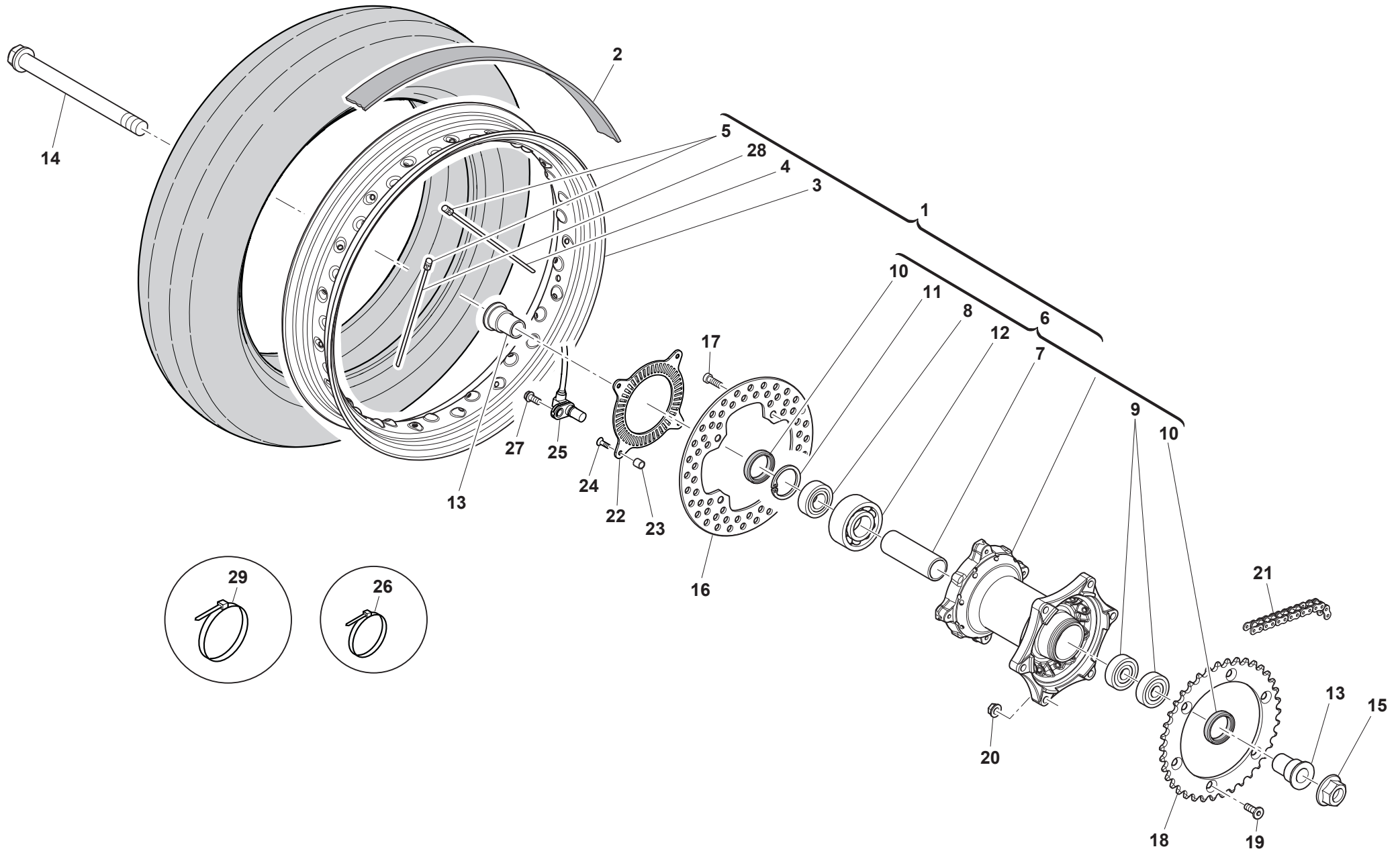



ACE OF SPADES

RUOTA POSTERIORE - REAR WHEEL
ROUE ARRIERE - HINTERRAD
RUEDA TRASERA

TAVOLA
DRAWING
TABLE
BILD
TABLA

25

Note Notes Marke Notas	Pos. No. N. Index Pos.	N. Cod. Code No. Nr. Code Code Nr N. Cod.	Q.tà Q.ty Q.te M.ge C.ad	DENOMINAZIONE	NAME	DESIGNATION	BESHREIBUNG	DENOMINACION
	1	F000A01831	1	RUOTA POSTERIORE COMPLETA	REAR WHEEL ASSY	ROUE ARRIÈRE COMPLÈTE	HINTERRAD KOMPLETT	RUEDA TRASERA COMPLETA
	2	8B0082879	1	PROTEZIONE CAMERA D'ARIA	AIR TUBE PROTECTION	VAINE DE PROTECTION	HULLE	VAINA DE PROTECCION
	3	F0A0P00262	1	CERCHIO RUOTA POST. 4,25"X17"	REAR WHEEL RIM 4,25"X17"	JANTE ROUE ARRIÈRE 4,25"X17"	FELGE HINTERRAD 4,25"X17"	LLANTA RUEDA TRAS. 4,25"X17"
	4	8000H1725	18	RAGGIO	SPOKE	BRAS	SPEICHE	RADIO
	5	69N429005	36	NIPPLO	NIPPLE	NIPPLE	NIPPEL	NIPLE
	6	F000A01827	1	MOZZO RUOTA POSTERIORE	REAR WHEEL HUB	MOYEU	NABE	CUBO
	7	800092414	1	DISTANZIALE INTERNO	INTERNAL SPACER	ENTRETOISE INTÉRIEUR	INTERNER ABSTANDHALTER	DISTANCIADOR INTERNO
	8	8B0026846	1	CUSCINETTO A SFERE Ø25x47x16	BALL BEARING Ø25x47x16	ROULEMENT À BILLES Ø25x47x16	KUGELLAGER Ø25x47x16	COJINETE DE BOLAS Ø25x47x16
	9	8A0026846	2	CUSCINETTO RADIALE	RADIAL BALL BEARING	ROULEMENT	LAGER	COJINETE
	10	800089572	2	ANELLO Ø47x32x7	RING Ø47x32x7	BAGUE Ø47x32x7	RING Ø47x32x7	ANILLO Ø47x32x7
	11	66N021272	1	ANELLO ELASTICO Ø50,5xSP1,75	CIRCLIP Ø50,5xTHK1,75	CIRCLIP Ø50,5xSP1,75	SPRENGRING Ø50,5xSP1,75	ANILLO ELASTICO Ø50,5xSP1,75
	12	F000P00121	1	PORTA DISTANZIALE	INNER SPACER SUPPORT	ENTRETOISE	ABSTANDHALTER	DISTANCIADOR
	13	F000P00713	2	DISTANZIALE ESTERNO	EXTERNAL SPACER	ENTRETOISE	ABSTANDHALTER	DISTANCIADOR
	14	70080069	1	PERNO RUOTA POSTERIORE	WHEEL AXLE	PIVOT DE ROUE	RADASCHE	EJE RUEDA
	15	72020318	1	DADO M20	NUT M20	ECROU M20	MUTTER M20	TUERCA M20
	16	800088887	1	DISCO FRENO POSTERIORE	REAR BRAKE DISC	DISQUE DE FREIN	BREMSSCHEIBE	DISCO FRENO
	17	800055878	4	VITE M6x11	SCREW M6x11	VIS M6x11	SCHRAUBE M6x11	TORNILLO M6x11
	18	8H0085291	1	CORONA DENTATA Z=40	CHAIN SPROCKET T=40	COURONNE DENTÉE D=40	ZAHNKRANZ Z=40	CORONA DENTADA Z=40
	19	8000H0158	6	VITE SPECIALE TSEI M8x28	SPECIAL SCREW TSEI M8x28	VIS TSEI M8x28	SCHRAUBE TSEI M8x28	TORNILLO TSEI M8x28
	20	Y00043928	6	DADO FLANGIATO M8	FLANGED NUT M8	ECROU BRIDE M8	FLANSCHMUTTER M8	TUERCA CON BRIDA M8
	21	F000P01134	1	CATENA 110 MAGLIE	CHAIN,110 PITCHES	CHAÎNE 110 MAILLONS	KETTE 110 GLIEDER	CADENA 110 ESLABONES
	22	F000P01033	1	RUOTA FONICA POSTERIORE	REAR TONE WHEEL	ROUE PHONIQUE ARRIERE	HINTERRAD IMPULSRAD	RUEDA FÓNICA TRASERA
	23	F000P01792	4	DISTANZIALE	SPACER	ENTRETOISE	ABSTANDHALTER	DISTANCIADOR
	24	8000H5785	4	VITE M4x12	BOLT M4x12	VIS M4x12	SCHRAUBE M4x12	TORNILLO M4x12
	25	E000P01022	1	SENSORE VELOCITÀ	SPEED SENSOR	CAPTEUR DE VITESSE	GESCHWINDIGKEITSSENSOR	SENSOR VELOCIDAD
	26	800056783	4	FASCETTA	CLAMP	COLLIER	SHELLE	ABRAZADERA
	27	Z00062726	1	VITE TEF M6x14	FLANGED EXAGON HEAD SCREW M6x14	BOULON DE BRIDE M6x14	FLANSCHENSCHRAUBE M6x14	TORNILLO DE REBORDE M6x14
	28	8000H1726	18	RAGGIO	SPOKE	BRAS	SPEICHE	RADIO
	29	800056444	1	FASCETTA CLIP	CLAMP	COLLIER	SHELLE	ABRAZADERA

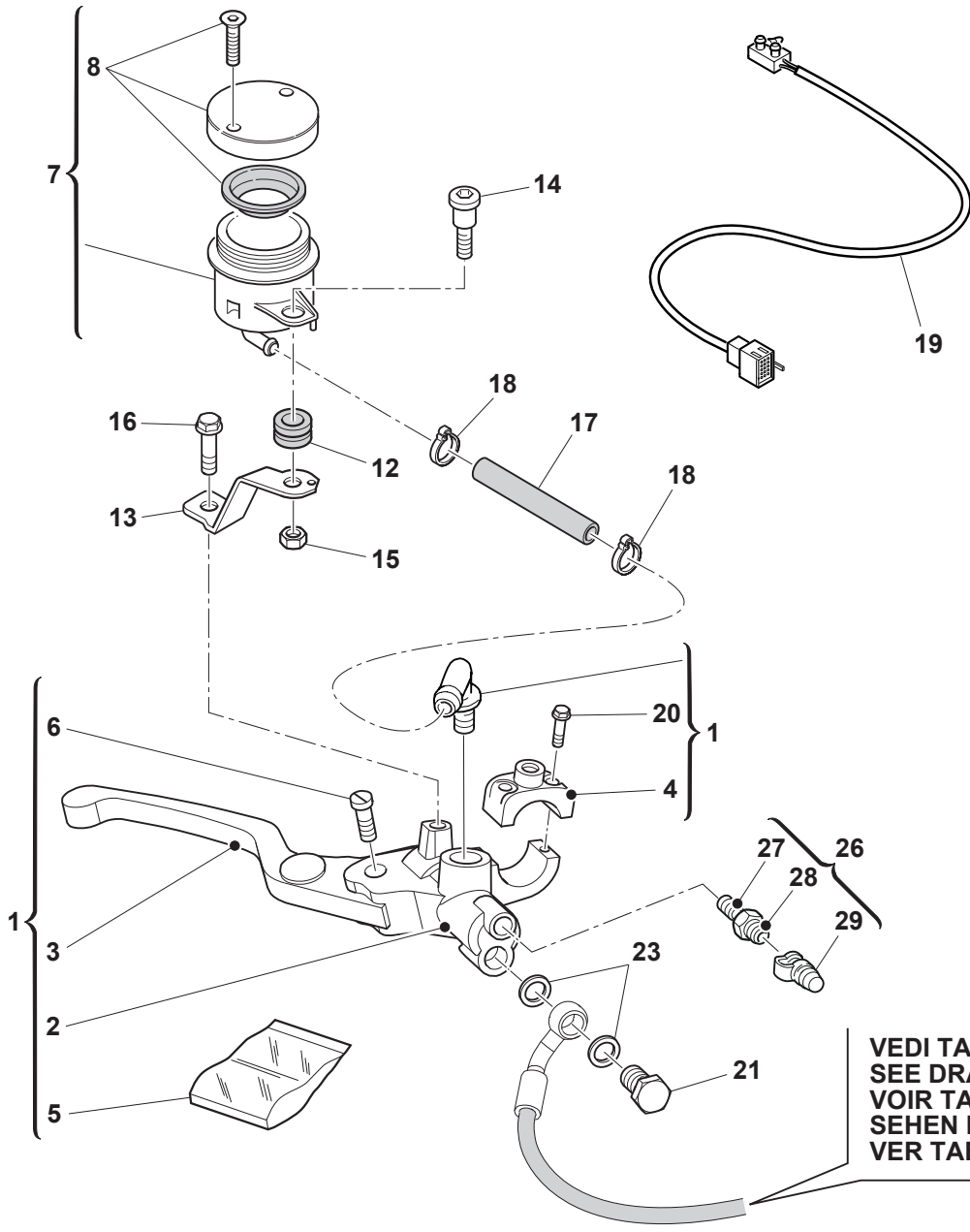

VEDI TAVOLA 22
SEE DRAWING 22
VOIR TABLE 22
SEHEN BILD 22
VER TABLA 22

VEDI TAVOLA 27A
SEE DRAWING 27A
VOIR TABLE 27A
SEHEN BILD 27A
VER TABLA 27A

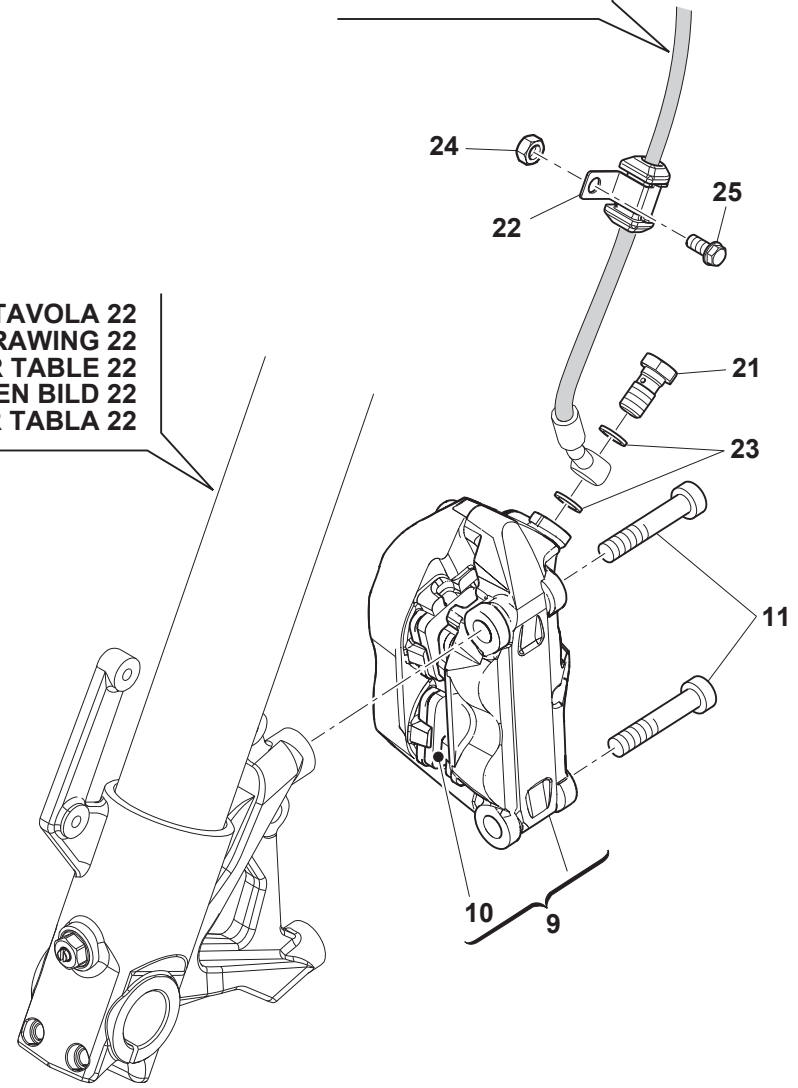

VEDI TAVOLA 27A
SEE DRAWING 27A
VOIR TABLE 27A
SEHEN BILD 27A
VER TABLA 27A



ACE OF SPADES

FRENO IDRAULICO ANTERIORE - FRONT HYDRAULIC BRAKE
FREIN HYDRAULIQUE AVANT - VORDERBREMSE
FRENO HIDRAULICO DELANTERO

TAVOLA
DRAWING
TABLE
BILD
TABLA

26

Note Notes Notes Marke Notas	Pos. No. N. Index Pos.	N. Cod. Code No. Nr. Code Code Nr N. Cod.	Q.tà Q.ty Q.te M.ge C.ad	DENOMINAZIONE	NAME	DESIGNATION	BESHREIBUNG	DENOMINACION
	1	8000A6075	1	ASSIEME POMPA FRENO ANTERIORE	MASTER CYLINDER ASSY	MAÎTRE-CYLINDRE DE FREIN COMPL.	ZUSAMMENBAU HAUPTBREMSZYLINDER	CONJUNTO BOMBA FRENO
	2	8000A6076	1	POMPA FRENO ANTERIORE	FRONT MASTER CYLINDER	MAÎTRE-CYLINDRE DE FREIN AVANT	HAUPTBREMSZYLINDER VORNE	BOMBA FRENO DELANTERO
	3	8000A7146	1	LEVA FRENO ANTERIORE	FRONT BRAKE LEVER	LEVIER	HEBEL	PALANCA
	4	8000A7147	1	CAVALLOTTO	CLAMP	BOULON	BÜGELSCHRAUBE	CABALLETE
	5	800042345	1	KIT REVISIONE RACCORDO	CONNECTION SET	GROUPE DE RÉVISION RACCORD	ANSCHLUSSSATZ	GRUPO REVISIÓN RACOR
	6	8000A7148	1	PERNO	PIN	AXE	BOLZEN	EJE
	7	800066181	1	SERBATOIO OLIO	OIL TANK	RÉSERVOIR D'HUILE	ÖLBEHÄLTER	DEPÓSITO ACEITE
	8	800068490	1	KIT REVISIONE TAPPO	REVISION KIT	GROUPE DE REVISION BOUCHON	STOPFENSATZ	GRUPO REVISION TAPON
	9	80A0A6078	1	PINZA FRENO ANTERIORE	FRONT BRAKE CALLIPER	ETRIER DE FREIN AVANT	BREMSSATTEL VORDERR	PINZA FRENO DELANTERO
	10	8A00A2040	1	COPPIA PASTIGLIE	PAIR OF BRAKE PADS	PAIRE PLAQUETTES	PAAR BREMSBELÄGE	PAREJA PASTILLAS
	11	YS0082751	2	VITE TCEIF M10x55	SCREW TCEIF M10x55	VIS TCEIF M10x55	SCHRAUBE TCEIF M10x55	TORNILLO TCEIF M10x55
	12	800033288	1	GOMMINO ANTIVIBRANTE	SILENT-BLOCK	ANTIVIBRATION	SCHWINGUNGSDAMFER	ANTIVIBRADOR
	13	8000A6229	1	PIASTRINA	PLATE	PLAQUETTE	PLÄTTCHEN	PLACA
	14	8000A1189	1	VITE	BOLT	VIS	SCHRAUBE	TORNILLO
	15	Z00056443	1	DADO AUTOBLOCCANTE M5	SELF-LOCKING NUT M5	ECROU AUTOBLOQUANT M5	SELBSTSICHERNDE MUTTER M5	TUERCA AUTOBLOCANTE M5
	16	Z00062725	1	VITE TEF M6x10	FLANGED EXAGON HEAD SCREW M6x10	BOULON DE BRIDE M6x10	FLANSCHENSCHRAUBE M6x10	TORNILLO DE REBORDE M6x10
	17	8G0066179	1	TUBO IN GOMMA L= 60 mm	PIPE L= 60 mm	TUBE L= 60 mm	ROHR L= 60 mm	TUBO L= 60 mm
	18	800018921	2	ANELLO ELASTICO	CIRCLIP	CIRCLIP	SPRENGRING	ANILLO ELASTICO
	19	8000A0929	1	INTERRUTTORE POMPA FRENO	FRONT BRAKE PUMP SWITCH	INTERRUPTEUR DE FREIN	SCHALTER	INTERRUPTOR FRENO
	20	Z00062729	2	VITE TEF M6x25	FLANGED EXAGON HEAD SCREW M6x25	BOULON DE BRIDE M6x25	FLANSCHENSCHRAUBE M6x25	TORNILLO DE REBORDE M6x25
	21	U00057155	2	VITE TE M10x19	HEXAGON SOCKET-HEAD BOLT M10x19	VIS M10x19	SCHRAUBE M10x19	TORNILLO M10x19
	22	73032259	2	FASCETTA	CLAMP	COLLIER	SHELLE	ABRAZADERA
	23	800021480	4	ROSETTA	WASHER	RONDELLE	UNTERLEGSSCHEIBE	ARANDELA
	24	Z00061355	1	DADO AUTOBLOCCANTE M5	SELF-LOCKING NUT M5	ECROU AUTOBLOQUANT M5	SELBSTSICHERNDE MUTTER M5	TUERCA AUTOBLOCANTE M5
	25	ZA0067997	1	VITE TEF M5x16	FLANGED EXAGON HEAD SCREW M5x16	BOULON DE BRIDE M5x16	FLANSCHENSCHRAUBE M5x16	TORNILLO DE REBORDE M5x16
	26	8000A3975	1	BOCCHETTONE SPURGO COMPLETO	COMPLETE BLEED FILLER	ORIFICE DE PURGE COMPLET	ENTLÜFTUNGSSTUTZEN KOMPLETT	BOCA PURGA COMPLETA
	27	8000A3976	1	BOCCHETTONE SPURGO	BRAKE OIL PIPE SCREW	ORIFICE DE PURGE	ENTLÜFTUNGSSTUTZEN	BOCA PURGA
	28	8000A3977	1	VALVOLA DI SPURGO	BLEEDING OIL VALVE	ROBINET DE PURGE	ENTLÜFTUNGSVENTIL	VÁLVULA DE PURGA
	29	800053259	1	PARAPOLVERE	DUST SEAL	CACHE-POUSSIÈRES	STAUBSCHUTZ	GUARDAPOLVO

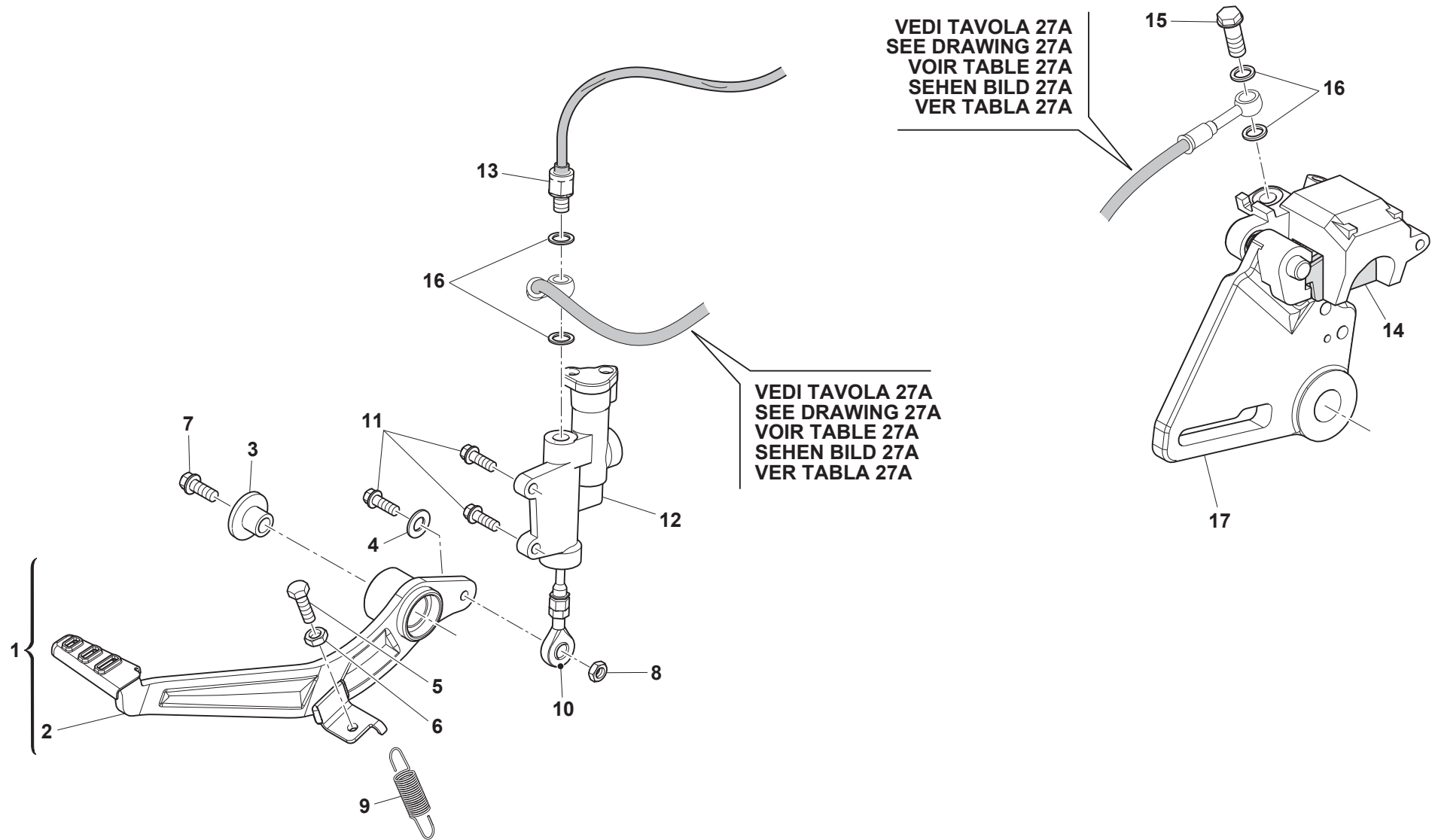

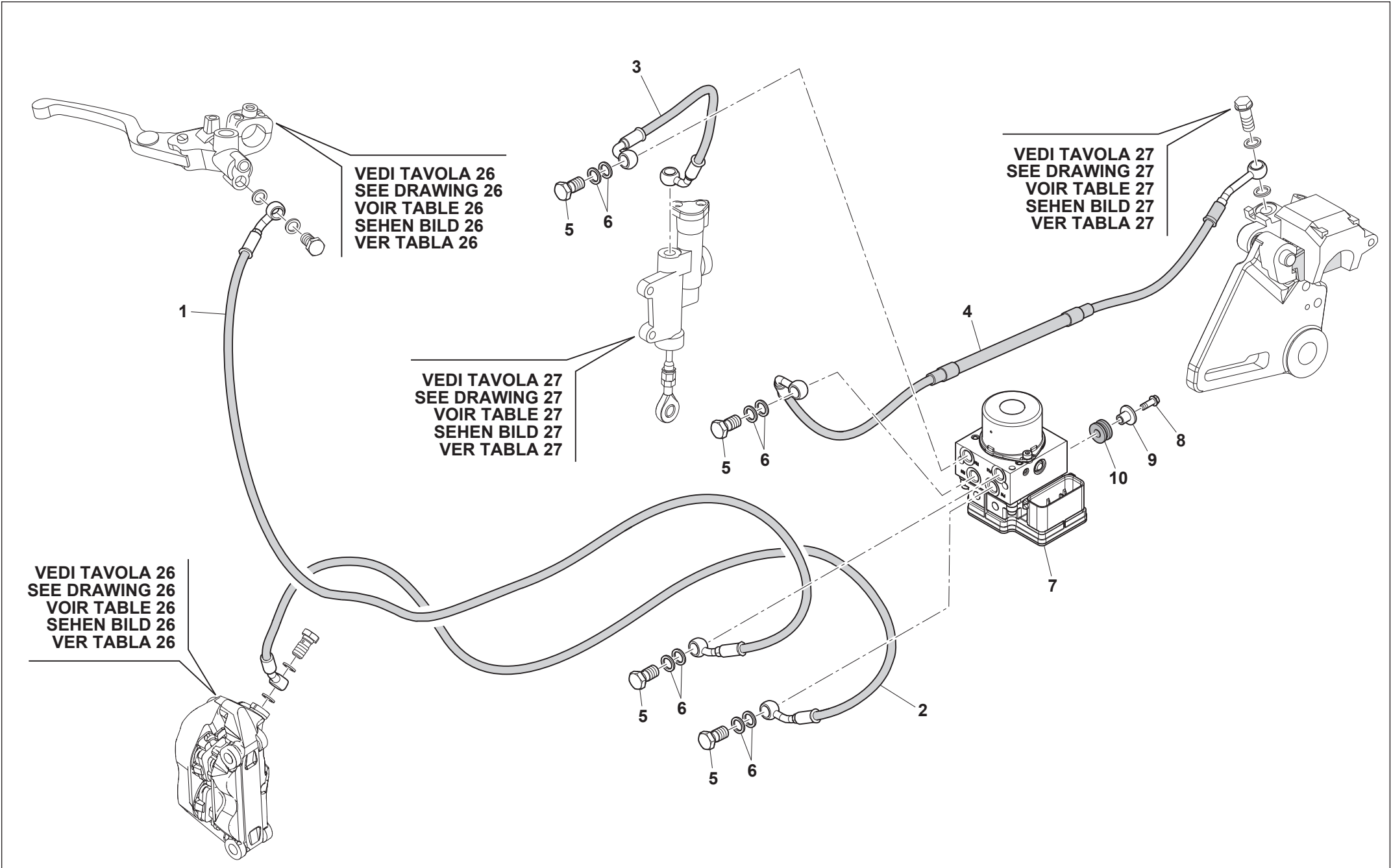

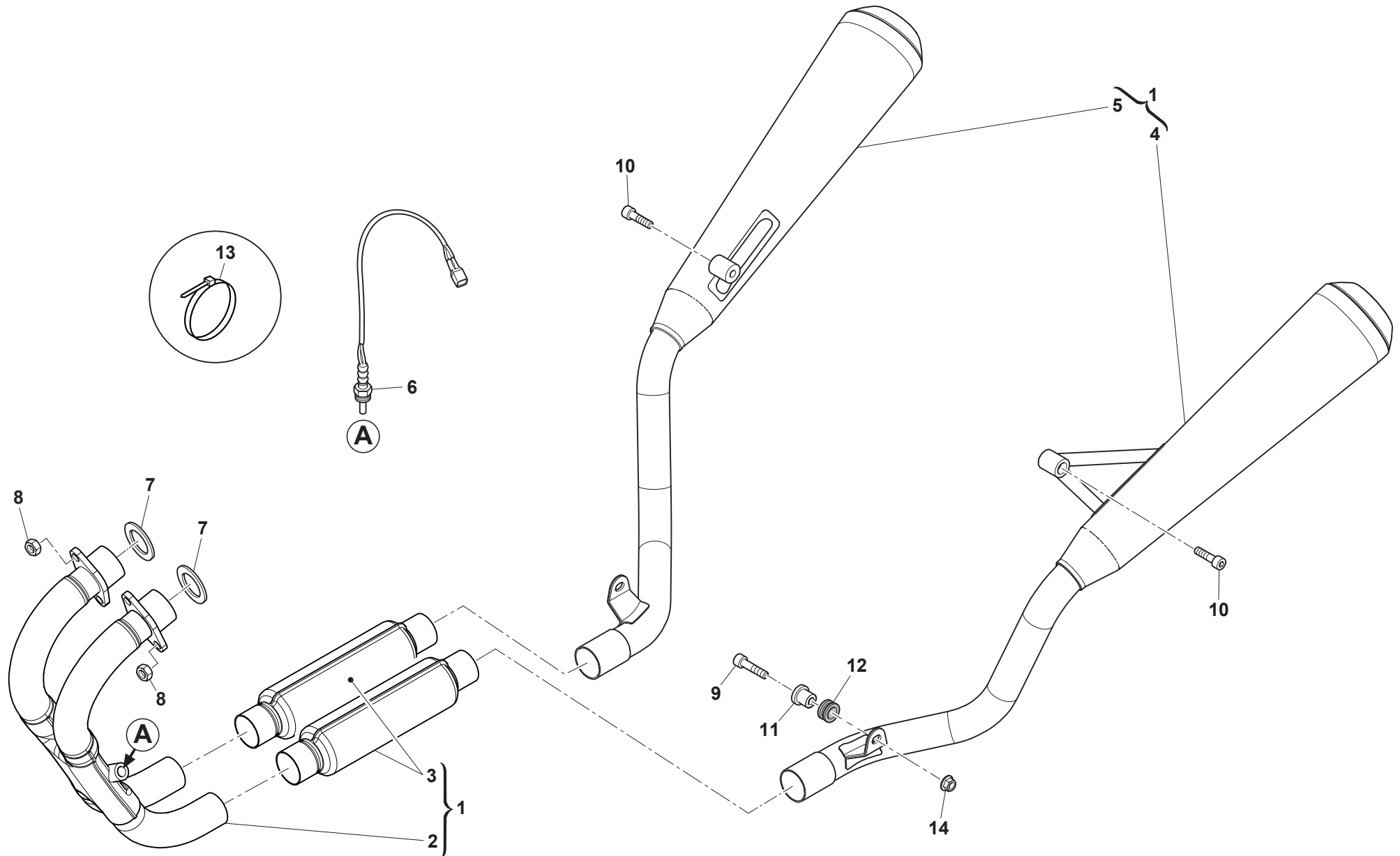

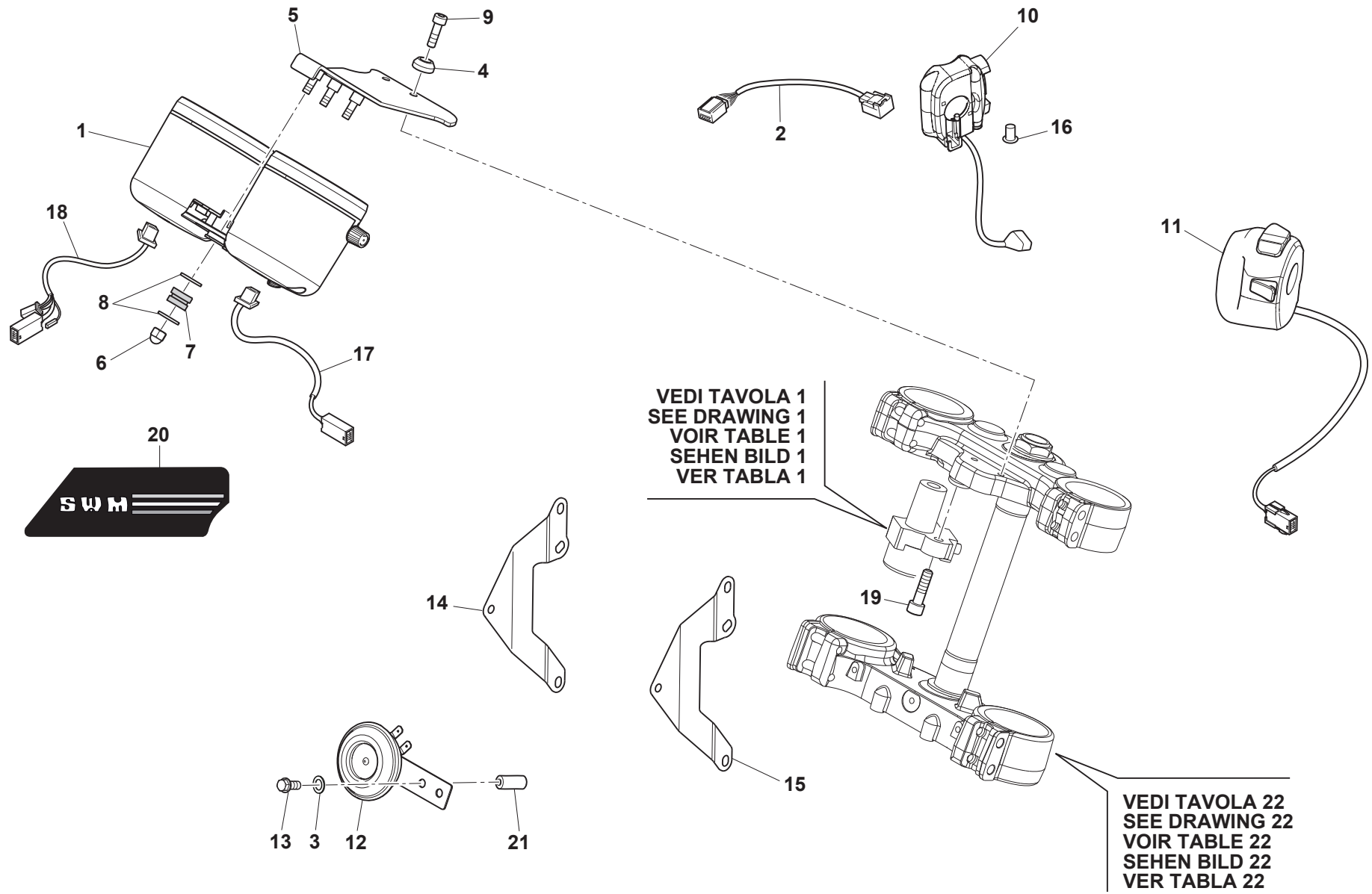



ACE OF SPADES

STRUMENTO DIGITALE - DIGITAL INSTRUMENT INSTRUMENT DIGITAL - DIGITAL TACHOMETER INSTRUMENTO DIGITAL

TAVOLA
DRAWING
TABLE
BILD
TABLA

29

Note Notes Notes Marke Notas	Pos. No. N. Index Pos.	N. Cod. Code No. Nr. Code Code Nr N. Cod.	Q.tà Q.ty Q.te M.ge C.ad	DENOMINAZIONE	NAME	DESIGNATION	BESHREIBUNG	DENOMINACION
	1	F0A0A01191	1	ASSIEME STRUMENTO	INSTRUMENT ASSY	INSTRUMENT ENSEMBLE	ZUSAMMENBAU INSTRUMENT	CONJUNTO INSTRUMENTO
	2	E000P03141	1	ADATTATORE	ADEPTER	ADAPTATEUR	ADAPTER	ADAPTADOR
	3	Z00045499	1	ROSETTA	WASHER	RONDELLE	UNTERLEGSCHIEBE	ARANDELA
	4	F000P00768	2	RONDELLA CONICA	CONIC SPACER	RONDELLE CONIQUE	UNTERLEGSCHIEBE	ARANDELA CONICA
	5	F000P00460	1	STAFFA	BRACKET	ETRIER	BÜGEL	ESTRIBO
	6	72020507	3	DADO M6	NUT M6	ECROU M6	MUTTER M6	TUERCA M6
	7	73012155	3	GOMMINO ANTIVIBRANTE	SILENT-BLOCK	ANTIVIBRATION	SCHWINGUNGSDAMFER	ANTIVIBRADOR
	8	Z00021535	6	ROSETTA Ø18x6x1,5	WASHER Ø18x6x1,5	RONDELLE Ø18x6x1,5	UNTERLEGSCHIEBE Ø18x6x1,5	ARANDELA Ø18x6x1,5
	9	60ND07335	2	VITE TCEI M6x20	SCREW TCEI M6x20	VIS TCEI M6x20	SCHRAUBE TCEI M6x20	TORNILLO TCEI M6x20
	10	E000P02185	1	COMMUTATORE DESTRO	RIGHT SWITCH	COMMUTATEUR DROIT	UMSCHALTER RECHTS	CONMUTADOR DERECHO
	11	F000P01808	1	COMMUTATORE SINISTRO	LEFT HANDLE SWITCH	COMMUTATEUR GAUCHE	UMSCHALTER LINKS	CONMUTADOR IZQUIERDO
	12	31080131	1	AVVISATORE ACUSTICO	HORN	AVERTISSEUR SONORE	HUPE	AVISADOR ACÚSTICO
	13	Z00062729	1	VITE TEF M6x25	FLANGED EXAGON HEAD SCREW M6x25	BOULON DE BRIDE M6x25	FLANSCHENSCHRAUBE M6x25	TORNILLO DE REBORDE M6x25
	14	F000P03142	1	TELAIETTO DI SOSTEGNO DESTRO	RIGHT HEAD LIGHT FRAME	SOUS-CHÂSSIS DE SUPPORT DROIT	STÜTZRAHMEN RECHTS	SUBCHASIS DE SUJECCIÓN DERECHO
	15	FA00P03142	1	TELAIETTO DI SOSTEGNO SINISTRO	LEFT HEAD LIGHT FRAME	SOUS-CHÂSSIS DE SUPPORT GAUCHE	STÜTZRAHMEN LINKS	SUBCHASIS DE SUJECCIÓN IZQUIERDO
	16	8000A1074	2	PIOLO IN GOMMA	RUBBER PIN	PLOT EN CAOUTCHOUC	GUMMIDÜBEL	CLAVIJA DE GOMA
	17	E000P01478	1	CAVO PER CONTACHILOMETRI	ODOMETER CABLE	CÂBLE POUR COMPTEUR KILOMÉTRIQUE	KABEL FÜR ODOMETER	CABLE DEL CUENTAKILÓMETROS
	18	E000P01479	1	CAVO PER CONTAGIRI	REV COUNTER CABLE	CÂBLE POUR COMPTE-TOURS	KABEL FÜR DREHZAHLMESSER	CABLE DEL CUENTAVUELTAS
	19	60ND02555	2	VITE TCEI M8x20	SCREW TCEI M8x20	VIS TCEI M8x20	SCHRAUBE TCEI M8x20	TORNILLO TCEI M8x20
	20	F000P01007	1	PIASTRA LOGO GM	GM LOGO PLATE	PLAQUE LOGO GM	PLATTE EMBLEM GM	PLACA LOGOTIPO GM
	21	FA00P00917	1	DISTANZIALE	SPACER	ENTRETOISE	ABSTANDHALTER	DISTANCIADOR

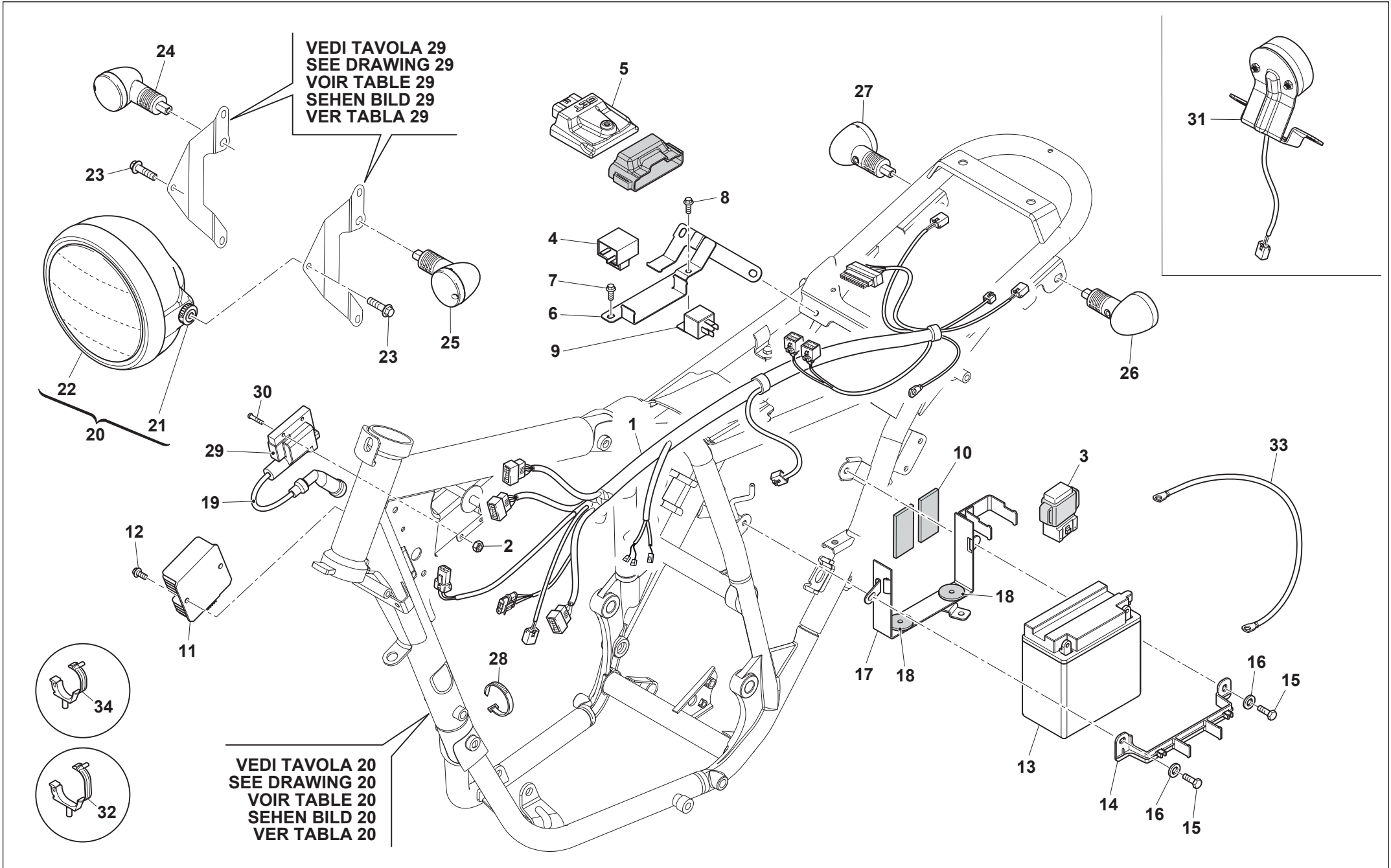



ACE OF SPADES

GRUPPO CAVI, PARTI ELETTRICHE - MAIN WIRING HARNESS, ELECTRICAL PARTS
CABLES PRINCIPAL, PARTIES ELECTRIQUES - KABEL, ELEKTRISCHE KOMPONENTE
GRUPO PRINCIPAL CABLES, PARTES ELECTRICAS

TAVOLA
DRAWING
TABLE
BILD
TABLA

30

Note Notes Notas	Pos. No. N. Index Pos.	N. Cod. Code No. Nr. Code Code Nr N. Cod.	Q.tà Q.ty Q.te M.ge C.ad	DENOMINAZIONE	NAME	DESIGNATION	BESHREIBUNG	DENOMINACION
	1	E000P02415	1	CABLAGGIO PRINCIPALE	MAIN CABLE HARNESS	CÂBLAGE PRINCIPAL	HAUPTVERKABELUNG	CABLEADO PRINCIPAL
	2	Z00040717	2	DADO AUTOBLOCCANTE M4	SELF-LOCKING NUT M4	ECROU AUTOBLOQUANT M4	SELBSTSICHERNDE MUTTER M4	TUERCA AUTOBLOCANTE M4
	3	E000P02437	1	TELERUTTORE AVVIAMENTO	SOLENOID STARTER	SOLENOÏDE DE DEMARRAGE	ANLASSER-FERNRELAIS	TELERRUPTOR ARRANQUE
	4	31040019	1	INTERMITTENZA	FLASHER	DISPOSITIF CLIGNOTANTS	BLINKGEBER	INTERMITENCIA
	5	E000P00814	1	CENTRALINA ELETTRONICA DA PROGRAMMARE	ELECTRONIC CONTROL UNIT TO BE PROGRAMMED	BOÎTIER ÉLECTRONIQUE A PROGRAMMER	STEUERELEKTRONIK ZU PROGRAMMIEREN	CENTRALITA ELECTRÓNICA PARA PROGRAMAR
	6	F000P00778	1	STAFFA FISSAGGIO ECU	BRACKET	ETRIER	BÜGEL	ESTRIBO
	7	Z00062726	3	VITE TEF M6x14	FLANGED EXAGON HEAD SCREW M6x14	BOULON DE BRIDE M6x14	FLANSCHENSCHRAUBE M6x14	TORNILLO DE REBORDE M6x14
	8	ZA0067997	1	VITE TEF M5x16	FLANGED EXAGON HEAD SCREW M5x16	BOULON DE BRIDE M5x16	FLANSCHENSCHRAUBE M5x16	TORNILLO DE REBORDE M5x16
	9	31190006	1	RELE POMPA BENZINA	RELAY FUEL PUMP	RELAIS POMPE À CARBURANT	BENZINPUMPE RELAIS	RELÉ BOMBA GASOLINA
	10	73012420	2	SPUGNA ADESIVA	SINGLE-SIDED ADHESIVE	ADHÉSIF EPONGE	KLEBEGUMMI	GOMAESPUMA ADESIVA
	11	31030087	1	REGOLATORE DI TENSIONE	VOLTAGE REGULATOR	RÉGULATEUR DE TENSION	SPANNUNGSREGLER	REGULADOR DE TENSIÓN
	12	72011991	2	VITE M6x12	SCREW M6x12	VIS M6x12	SCHRAUBE M6x12	TORNILLO M6x12
	13	31070060	1	BATTERIA	BATTERY	BATTERIE	BATTERIE	BATERÍA
	14	73021083	1	STAFFA FISSAGGIO BATTERIA	BRACKET	ETRIER	BÜGEL	ESTRIBO
	15	Z00062726	3	VITE TEF M6x14	FLANGED EXAGON HEAD SCREW M6x14	BOULON DE BRIDE M6x14	FLANSCHENSCHRAUBE M6x14	TORNILLO DE REBORDE M6x14
	16	Z00021535	2	ROSETTA	WASHER	RONDELLE	UNTERLEGSCHIEBE	ARANDELA
	17	F000P01643	1	SUPPORTO BATTERIA	BATTERY SUPPORT	SUPPORT BATTERIE	BATTERIE HALTERUNG	SOPORTE BATERÍA
	18	73010197	2	GOMMINO APPOGGIO BATTERIA	DAMPING MAT, BATTERY	JOINT EN CAOUTCHOUC	GUMMISCHEIBE	GOMA
	19	31350069	1	CAVO ALTA TENSIONE	HIGH VOLTAGE WIRE	CÂBLE	KABEL	CABLE
	20	F000A00848	1	FANALE ANTERIORE COMPLETO	COMPLETE FRONT HEADLAMP	FEU AVANT COMPLET	FRONTSCHIEBWERFER KOMPLETT	FARO DELANTERO COMPLETO
	21	73012493	2	GOMMINO	RUBBER RING	JOINT EN CAOUTCHOUC	GUMMISCHEIBE	GOMA
	22	F000A00848	1	FANALE ANTERIORE	FRONT HEADLAMP	FEU AVANT	FRONTSCHIEBWERFER	FARO DELANTERO
	23	8A00B1959	2	VITE TEF M8x30	FLANGED EXAGON HEAD SCREW M8x30	BOULON DE BRIDE M8x30	FLANSCHENSCHRAUBE M8x30	TORNILLO DE REBORDE M8x30
	24	F000P01814	1	INDICATORE ANT. DX	RH FRONT INDICATOR	CLIGNOTANT AV. DROITE	RICHTUNGSANZEIGER VORNE RE	INTERMITENTE DEL. DER.
	25	F000P01815	1	INDICATORE ANT. SX	LH FRONT INDICATOR	CLIGNOTANT AV. GAUCHE	RICHTUNGSANZEIGER VORNE LI	INTERMITENTE DEL. IZQ.
	26	F000P01816	1	INDICATORE POST. SX	LH REAR INDICATOR	CLIGNOTANT AR. GAUCHE	RICHTUNGSANZEIGER HINTEN LI	INTERMITENTE TRAS. IZQ.
	27	F000P01817	1	INDICATORE POST. DX	RH REAR INDICATOR	CLIGNOTANT AR. DROITE	RICHTUNGSANZEIGER HINTEN RE	INTERMITENTE TRAS. DER.
	28	800056444	11	FASCETTA L=188 mm	CLAMP L=188 mm	COLLIER L=188 mm	SHELLE L=188 mm	ABRAZADERA L=188 mm
	29	31020123	1	BOBINA	COIL	BOBINE	ZÜNDSPULE	BOBINA
	30	72030698	2	VITE M4x20	SCREW M4x20	VIS M4x20	SCHRAUBE M4x20	TORNILLO M4x20
	31	F000A02288	1	FANALE POSTERIORE	TAIL LIGHT	FEU ARRIÈRE	HECKSCHIEBWERFER	PILOTO TRASERO
	32	8A0060283	1	FASCETTA	CLAMP	COLLIER	SHELLE	ABRAZADERA

